

# HEMNES

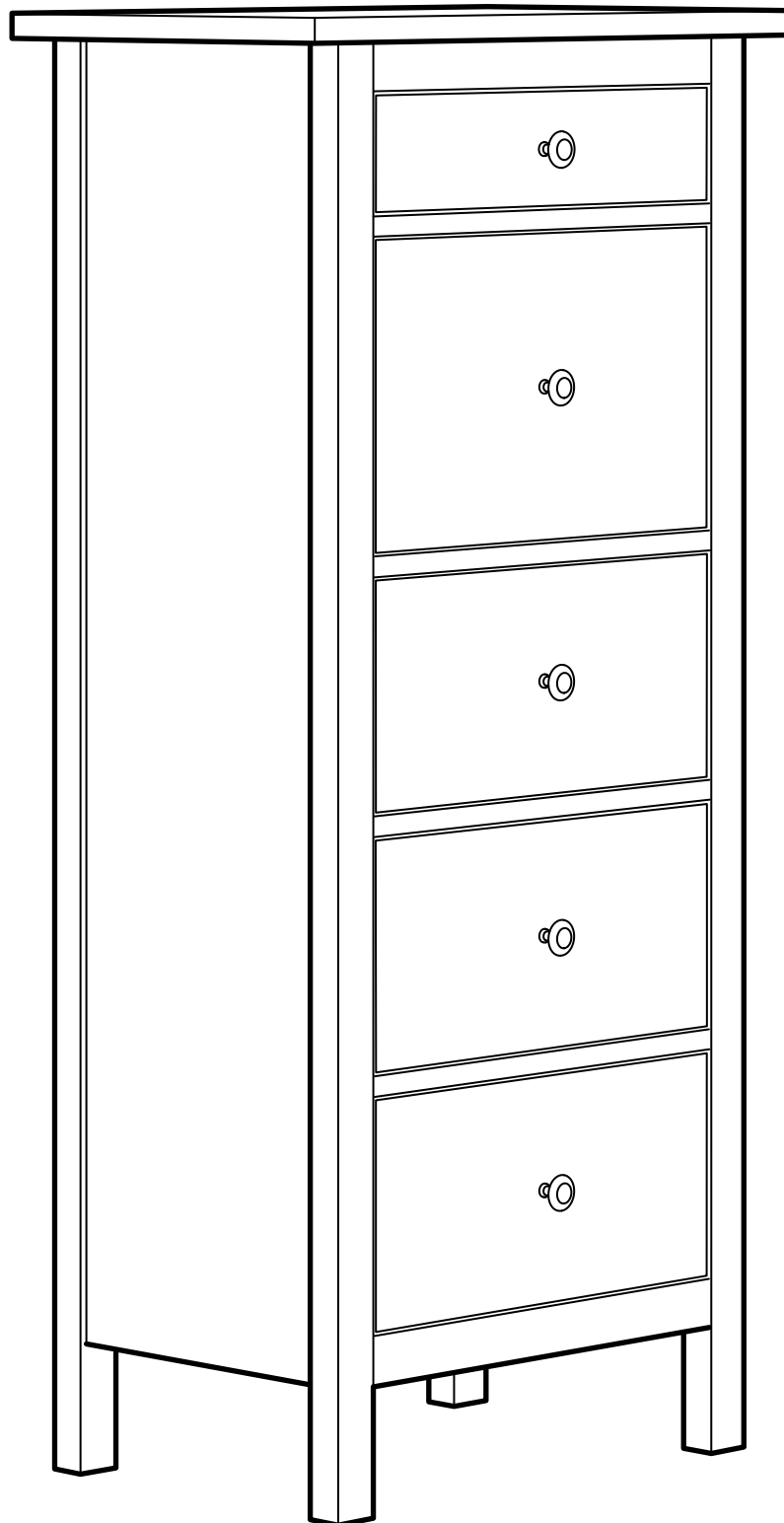

Design and Quality  
IKEA of Sweden



ENGLISH

## WARNING

**Serious or fatal crushing injuries can occur from furniture tip-over. ALWAYS secure this furniture to the wall using tip-over restraints. To further reduce the risk of serious injury and death from tip-overs:**

- Place heaviest items in the lower drawer.
- Do not set TVs or other heavy objects on top of this product.
- Never let children climb or hang on drawers, doors, or shelves.

DEUTSCH

## ACHTUNG

**Umfallende Möbelstücke können lebensgefährlich sein. Um diesem Risiko zu entgehen, muss das Möbel UNBEDINGT mit dem beige-packten Kippschutz an der Wand befestigt werden. Um das Risiko schwerer oder gar tödlicher Verletzungen durch umkippende Möbelstück weiter zu mindern, bitte Folgendes beachten:**

- Schwere Gegenstände immer in Bodennähe aufbewahren.
- Fernsehgeräte oder andere schwere Geräte niemals auf das Produkt stellen.
- Kindern niemals erlauben, auf Schubladen, Türen und Regale zu klettern oder sich daranzuhängen.

FRANÇAIS

## ATTENTION

**Risque de blessures graves ou mortelles en cas de basculement du meuble. TOUJOURS fixer ce meuble au mur à l'aide des fixations anti-basculement. Pour encore réduire les risques de blessures graves ou mortelles dus au basculement du meuble :**

- Placer les objets les plus lourds dans le tiroir du bas.
- Ne pas poser de TV ou d'objet lourd sur le dessus de ce produit.
- Ne jamais laisser les enfants grimper ou s'accrocher aux tiroirs, portes ou tablettes.

NEDERLANDS

## WAARSCHUWING

**Opbergmeubels die omvallen kunnen ernstig of levensbedreigend letsel veroorzaken. Om dat te voorkomen dient het meutel ALTIJD met het meegeleverde kantelbeslag aan de muur te worden bevestigd. Om het risico op kantelende voorwerpen en daarmee ernstig letsel of dodelijke ongevallen nog verder te vermijden, is het verstandig hiermee rekening te houden:**

- Plaats zware voorwerpen altijd helemaal onderin.
- Zet nooit een tv of andere zware voorwerpen op het meubel.
- Sta niet toe dat kinderen op lades, deuren of planken klimmen of eraan gaan hangen.

DANSK

## ADVARSEL

**Der kan opstå alvorlig eller livsfarlig tilskadekomst, hvis møblet vælter. Møblet skal ALTID fastgøres til væggen med væltesikringer. For yderligere at reducere risikoen for alvorlig tilskadekomst og dødsfald som følge af vælteulykker:**

- Placer de tungeste ting i de nederste skuffer.
- Placer ikke et tv eller andre tunge genstande oven på dette produkt.
- Sørg for, at børn ikke klatrer eller hænger i skuffer, låger eller hylder.

ÍSLENSKA

## AÐVÖRUN

**Alvarleg eða lífshættuleg meiðsli geta orðið ef húsgagn fellur fram fyrir sig. Þetta húsgagn á alltaf að vera fest við vegg með festingum. Til að draga úr hættu á alvarlegum meiðslum og dauða vegna falls húsgagns:**

- Settu þyngstu hlutina í neðstu skúffuna.
- Ekki setja sjónvarp eða aðra þunga hluti ofan á húsgagnið.
- Aldrei leyfa börnum að klifra eða hanga á skúffum, hurðum eða hillum.



NORSK

## ADVARSEL

Oppbevaringsmøbler som velter kan forårsake alvorlige eller livstruende skader. For å unngå dette skal du **ALLTID** feste møblene i veggen med de inkluderte beslagene. For å redusere faren ytterligere for at veltende gjenstander forårsaker alvorlige eller dødelige skader:

- Plasser alltid tunge gjenstander nederst.
- Plasser aldri TV-apparater eller andre tunge gjenstander oppå møbelet.
- La aldri barn klatre eller henge på skuffer, dører eller hyller.

SUOMI

## VAROITUS

Kalusteen kaatuminen voi aiheuttaa vakavia vammoja. Kiinnitä **AINA** kaluste seinään kaatumisesteellä. **Pientääksesi kaatumisriskiä:**

- Sijoita painavimmat esineet alalaatikoille.
- Älä sijoita televisiota tai muita painavia esineitä tämän tuotteen päälle.
- Älä koskaan anna lasten kiipeillä tai roikkua laatikoissa, ovissa tai hyllyillä.

SVENSKA

## VARNING

Förvaringsmöbler som välter kan orsaka allvarliga eller livshotande skador. För att undvika detta ska du **ALLTID** fästa möbeln i väggen med de tipskyddsbeslag som medföljer. För att ytterligare minimera risken för att vältande föremål orsakar allvarliga eller dödliga skador bör du tänka på följande:

- Placera alltid tunga föremål längst ner.
- Placera aldrig TV-apparater eller andra tunga föremål ovanpå möbeln.
- Tillåt aldrig barn att klättra eller hänga på lådor, dörrar eller hyllor.

ČESKY

## UPOZORNĚNÍ!

Převržení nábytku může mít vážné nebo fatální následky. Tento nábytek **VŽDY** připevněte ke stěně pomocí kotvících úchytlů proti převržení. **Abyste ještě více snížili riziko vážných zranění a smrti z převrácení nábytku:**

- Nejtěžší věci dávejte do nejnižší zásuvky.
- Nedávejte na tento výrobek televizi nebo jiné těžké předměty.
- Nikdy nenechávejte děti šplhat nebo se věšet na zásuvky, dvířka a police.

ESPAÑOL

## ADVERTENCIA

Si el mueble volcase, podría provocar lesiones graves e incluso mortales.

Sujeta **SIEMPRE** este mueble a la pared utilizando los herrajes antivuelco.

Para reducir aún más el riesgo de sufrir lesiones graves o mortales debido al vuelco del mueble:

- Pon los objetos más pesados en el cajón inferior.
- No pongas un TV u otros objetos pesados encima de este producto.
- Evita que los niños se cuelguen o trepen por los cajones, puertas o estantes.

ITALIANO

## AVVERTENZA

Se il mobile si ribalta può causare lesioni da schiacciamento gravi o mortali.

Fissa **SEMPRE** questo mobile alla parete usando gli accessori antiribaltamento. Per ridurre ulteriormente il rischio di lesioni gravi o mortali causate dal ribaltamento:

- Metti gli oggetti più pesanti nel cassetto inferiore.
- Non collocare la TV o altri oggetti pesanti sopra questo prodotto.
- Evita che i bambini si appendano o si arrampichino sui cassetti, sulle ante o sui ripiani.

MAGYAR

## FIGYELEM!

A bútor felborulása súlyos, akár életveszélyes sérüléseket okozhat. **MINDIG** rögzítsd biztonságosan a falhoz a bútort, ehhez használd felborulás gátló kellékeket. **A felborulás miatti sérülések kockázata tovább csökkenthető:**

- A legnehezebb tárgyakat az alsó fiókokba tedd.
- Ne helyezz TV-t, vagy egyéb nehéz tárgyat a bútor tetejére.
- Soha ne engedd, hogy a gyerekek a fiókokon, ajtókon, polcokon felmászanak, rajtuk függeszkedjenek.

POLSKI

## OSTRZEŻENIE

Na skutek przewrócenia się mebla może dojść do poważnych lub śmiertelnych obrażeń ciała. **ZAWSZE** przymocuj ten mebel do ściany za pomocą ograniczników. **Aby dodatkowo ograniczyć ryzyko poważnych obrażeń ciała i śmierci na skutek przewrócenia się mebla:**

- Najcięższe przedmioty umieść w dolnej szufladzie.
- Nie stawiaj na meblu telewizora, ani innych ciężkich przedmiotów.
- Nigdy nie pozwalaj dzieciom wspinać się na szuflady, drzwiczki lub półki.



EESTI

## HOIATUS

**Mööbli ümberkukkumisel võite saada tõsiseid või surmavaid vigastusi.**

**ALATI kinnitage mööbel seina külge, kasutades kukkumist takistavaid kinnitusi. Selleks, et veelgi enam vähendada kukkumisriski ja vigastusi:**

- Pange rasked esemed alumisse riiulisse.
- Ärge pange telerit või teisi raskeid esmeid selle toote peale.
- Ärge kunagi laske lastel sahtlite, uste või riiulite peal kõikuda või ronida.

LATVIEŠU

## UZMANĪBU

**Mēbelēm apgāžoties, iespējams gūt nopietnas vai nāvējošas traumas.**

**VIENMĒR nostipriniet mēbeles pie sienas, izmantojot stiprinājumus. Lai maksimāli izvairītos no nopietnu vai nāvējošo traumu riska, mēbelēm apgāžoties:**

- Novietojiet smagākos priekšmetus apakšējās atvilktnēs.
- Virs preces nenovietojiet televizorus vai citus smagus objektus.
- Nekādā gadījumā neļaujiet bērniem rāpties vai karāties uz atvilktnēm, durvīm un plauktiem.

LIETUVIŲ

## DĖMESIO

**Užvirtus baldui gresia rimti sužalojimai ar net mirtis.**

**VISADA pritvirtinkite tokius baldus prie sienos naudodami tam skirtus laikiklius. Taip pat reikėtų laikytis ir kitų rekomendacijų, kad baldai neužvirtų:**

- Sunčiausius daiktus laikykite apatiniamie stalčiuje.
- Ant šio ir panašių baldų nelaikykite sunkių daiktų, pavyzdžiui, televizoriaus.
- Neleiskite vaikams lipti / karstyti ant stalčių, durelių ar lentynų.

PORTUGUÊS

## IMPORTANTE

**A queda de móveis pode provocar ferimentos graves ou fatais. Fixe SEMPRE este móvel à parede com acessórios de fixação. Para reduzir o risco de ferimentos graves ou morte por queda de móveis:**

- Coloque os itens mais pesados nas gavetas mais baixas.
- Não coloque televisões ou outros objetos pesados em cima deste artigo.
- Nunca permita que as crianças subam ou se pendurem nas gavetas, portas e prateleiras.

ROMÂNĂ

## ATENȚIE

**Piese de mobilier grele pot provoca răni. Prinde ÎN-TOTDEAUNA mobilierul de perete cu dispozitivele potrivite de prindere. Pentru a reduce riscul de accidente:**

- Așază obiectele grele pe rafturile inferioare
- Nu așeza televizorul pe raftul de deasupra.
- Nu lăsa copiii să se urce pe sertare sau polițe.

SLOVENSKY

## UPOZORNENIE

**Pri prevrátení nábytku hrozí vážne až smrteľné poranenie. Nábytok ZA KAŽDÝCH OKOLNOSTÍ do steny ukotvite. S cieľom eliminovať riziko vážneho poranenia či úmrtia v dôsledku prevrátenia nábytku, dbajte na nasledujúce zásady:**

- Najťažšie predmety umiestňujte do spodnej zásuvky.
- Na vrch nábytku nepokladajte televízor ani iné ťažké predmety.
- Dbajte, aby deti nelózili na nábytok, aby sa nevešali na zásuvky, dvierka ani police.

БЪЛГАРСКИ

## ВНИМАНИЕ

**Сериозни или фатални инциденти могат да бъдат предизвикани при преобръщането на мебелите. ВИНАГИ закрепвайте тези мебели към стената, като използвате скоби. За да намалите риска от сериозни наранявания и фатални инциденти при преобръщане:**

- Поставете най-тежките предмети в най-долните чекмеджета.
- Не поставяйте телевизор или други тежки предмети върху продукта.
- Не позволявайте на децата да се катерят или да се провисват на чекмеджета, врати или рафтове.

HRVATSKI

## UPOZORENJE

**Namještaj koji se prevrne može uzrokovati ozbiljne ili smrtonosne ozljede. UVIJEK pričvrstite namještaj na zid s pomoću priloženih pričvrstnika. Za smanjenje rizika od ozbiljnih ili smrtonosnih ozljeda:**

- Postaviti najteže predmete u najnižu ladicu.
- Ne postavljati TV ili druge teške predmete na ovaj proizvod.
- Ne dozvoliti djeci da se penju na ladice, vrata ili police ili vješaju o njih.



ΕΛΛΗΝΙΚΑ

## ΠΡΟΕΙΔΟΠΟΙΗΣΗ

Μπορεί να προκληθούν σοβαροί ή θανάσιμοι τραυματισμοί από τυχόν ανατροπή του επίπλου. ΠΑΝΤΑ να ασφαρίζετε αυτό το έπιπλο στον τοίχο χρησιμοποιώντας τα εξαρτήματα στερέωσης. Για να ελαχιστοποιήσετε τον κίνδυνο τραυματισμού από ανατροπή:

- Τοποθετήστε τα πιο βαριά αντικείμενα στο πιο χαμηλό συρτάρι.
- Μην τοποθετείτε τηλεοράσεις ή άλλα βαριά αντικείμενα στο πάνω μέρος αυτού του προϊόντος.
- Ποτέ μην αφήνετε τα παιδιά να σκαρφαλώσουν ή να κρεμαστούν στα συρτάρια, στις πόρτες ή στα ράφια.

РУССКИЙ

## ВНИМАНИЕ!

Опрокидывание мебели может стать причиной получения серьезных травм и привести к смерти. Чтобы предотвратить опрокидывание, ВСЕГДА крепите мебель к стене с помощью аксессуаров, предотвращающих опрокидывание. В целях принятия мер дополнительной безопасности для предотвращения опрокидывания:

- Храните тяжелые предметы в нижнем ящике.
- Не ставьте телевизор или другие тяжелые предметы сверху.
- Никогда не позволяйте детям залезать на ящики, дверцы или полки, а также виснуть на них.

SRPSKI

## UPOZORENJE

Prevrtnanje nameštaja može da izazove nastanak ozbiljnih ili fatalnih povreda. UVEK pričvrstite ovaj nameštaj za zid pomoću fiksatora koji sprečavaju njegovu prevrtnanje. Da bi se izbegla opasnost od teških povreda i smrti usled prevrtnanja nameštaja uvek:

- Najteže predmete stavljaj u najnižu fioku.
- Ne stavljaj TV niti druge teške predmete na vrh ovog proizvoda.
- Ne dozvoljavaj deci da se penju niti vise na fiokama, vratima ni policama.

SLOVENŠČINA

## OPOZORILO

Prevrnitev pohištva lahko privede do hudih telesnih poškodb ali smrti. VEDNO pritrđi ta kos pohištva v steno z varovali proti prevrnitvi. Dodatni ukrepi za zmanjšanje možnosti resnih ali smrtnih poškodb zaradi prevrnitve pohištva:

- težje predmete shranjaj v spodnjem predalu;
- na ta izdelek ne nameščaj televizorja in ne odlagaj drugih težkih predmetov;
- otrokom prepričaj, da bi plezali ali se obešali na predale, vrata ali police.

TÜRKÇE

## UYARI

Mobilyaların devrilmesi sonucunda ezilemeye bağlı ciddi veya ölümcül yaralanmalar meydana gelebilir. Mobilyayı DAİMA devrilme önleyici aparat kullanarak duvara sabitleyiniz. Devrilmelere bağlı ciddi yaralanma ve ölüm riskini daha da azaltmak için:

- Ağır eşyaları alt çekmecelere yerleştiriniz.
- TV veya diğer ağır nesnelere bu ürün üzerine yerleştirmeyiniz.
- Çocukların çekmecelere, kapaklara veya raflara tırmanmasına veya asılmalarına kesinlikle izin vermeyiniz.

عربي

## تحذير

مخاطر تعرض لإصابات خطيرة نتيجة انقلاق الأثاث. يجب تثبيت هذا الأثاث دائماً على الحائط بواسطة أدوات التثبيت. لتقليل مخاطر الإصابة الخطيرة والتعرض للموت نتيجة انقلاق الأثاث:

- ضع الأثاث الثقيل في الدرج السفلي.
- لا تضعي تلفزيون أو أي أشياء ثقيلة أخرى فوق هذا المنتج.
- لا تسمحني أبداً للأطفال بتسلق أو التعلق على الأدراج، الأبواب، أو الأرفف.

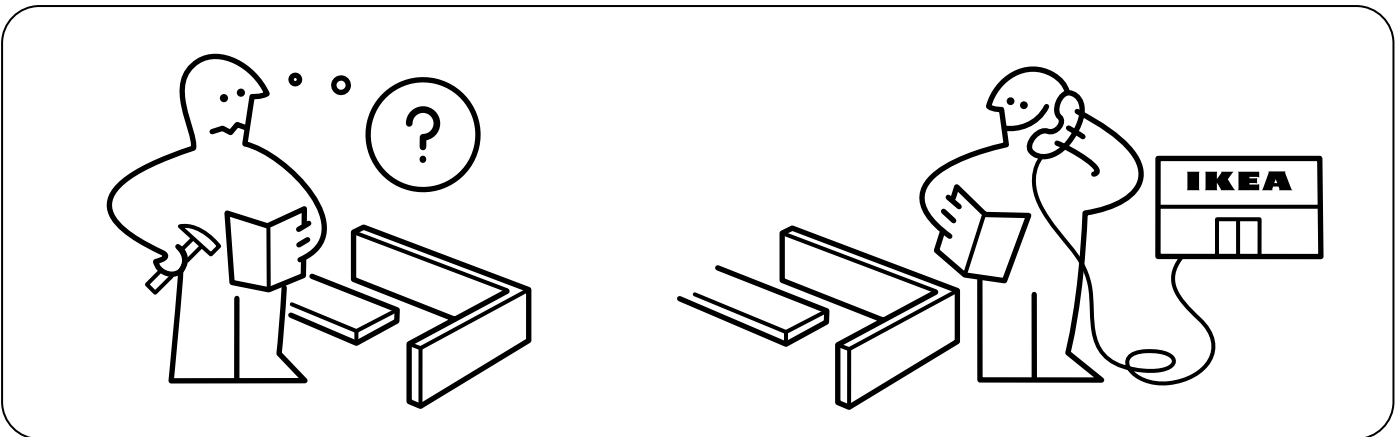
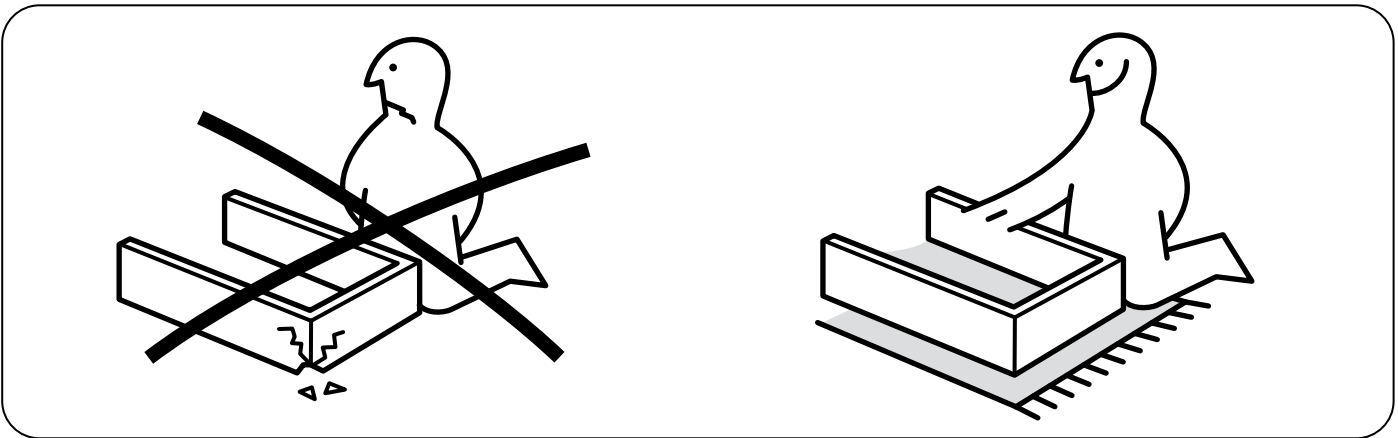
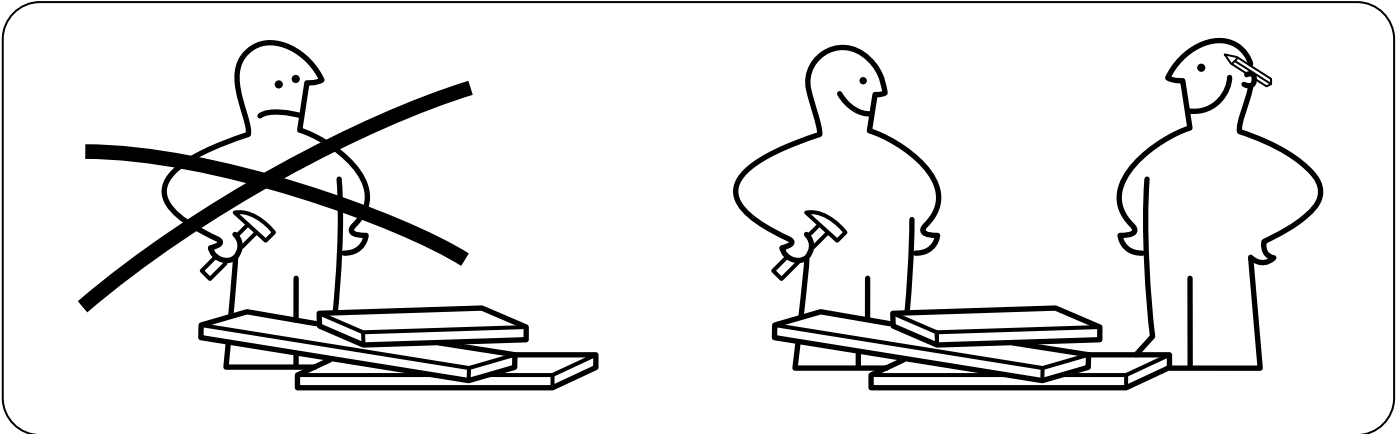
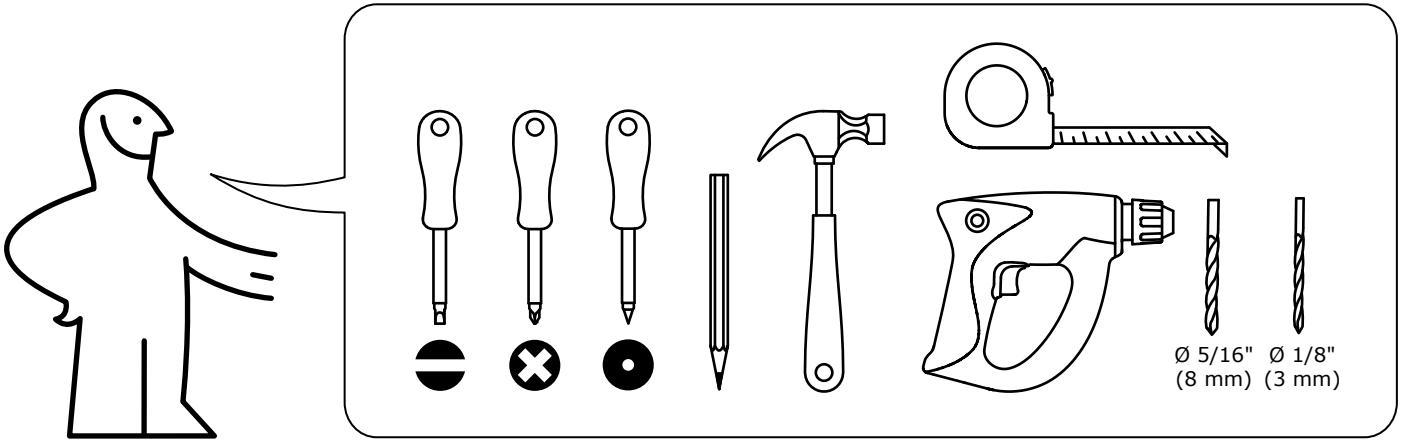

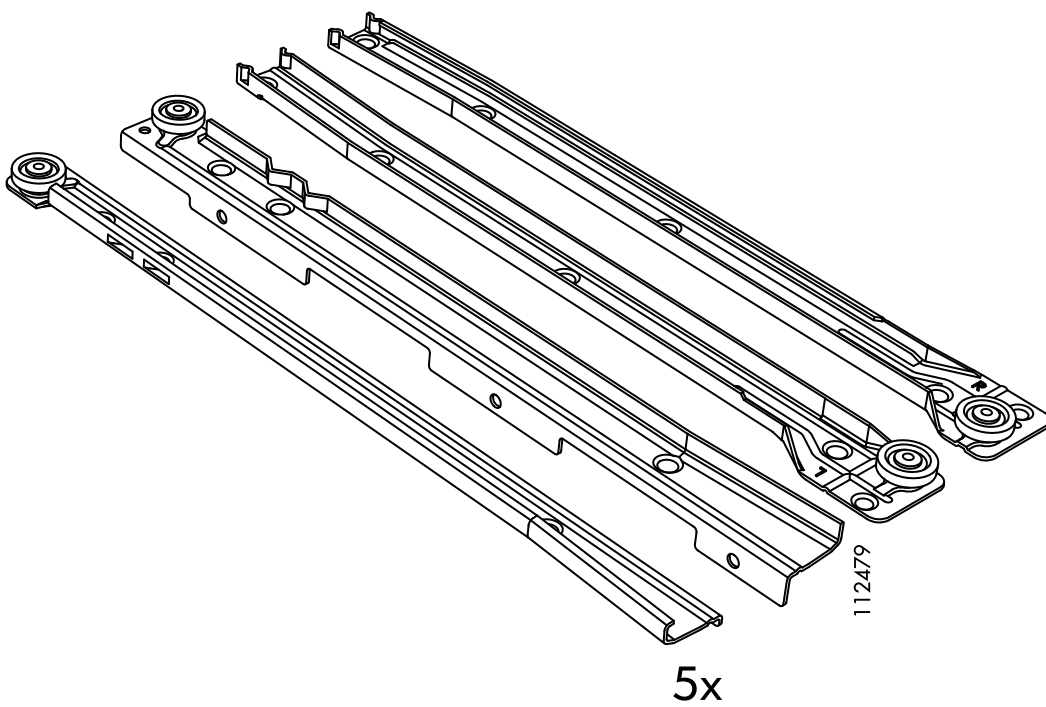
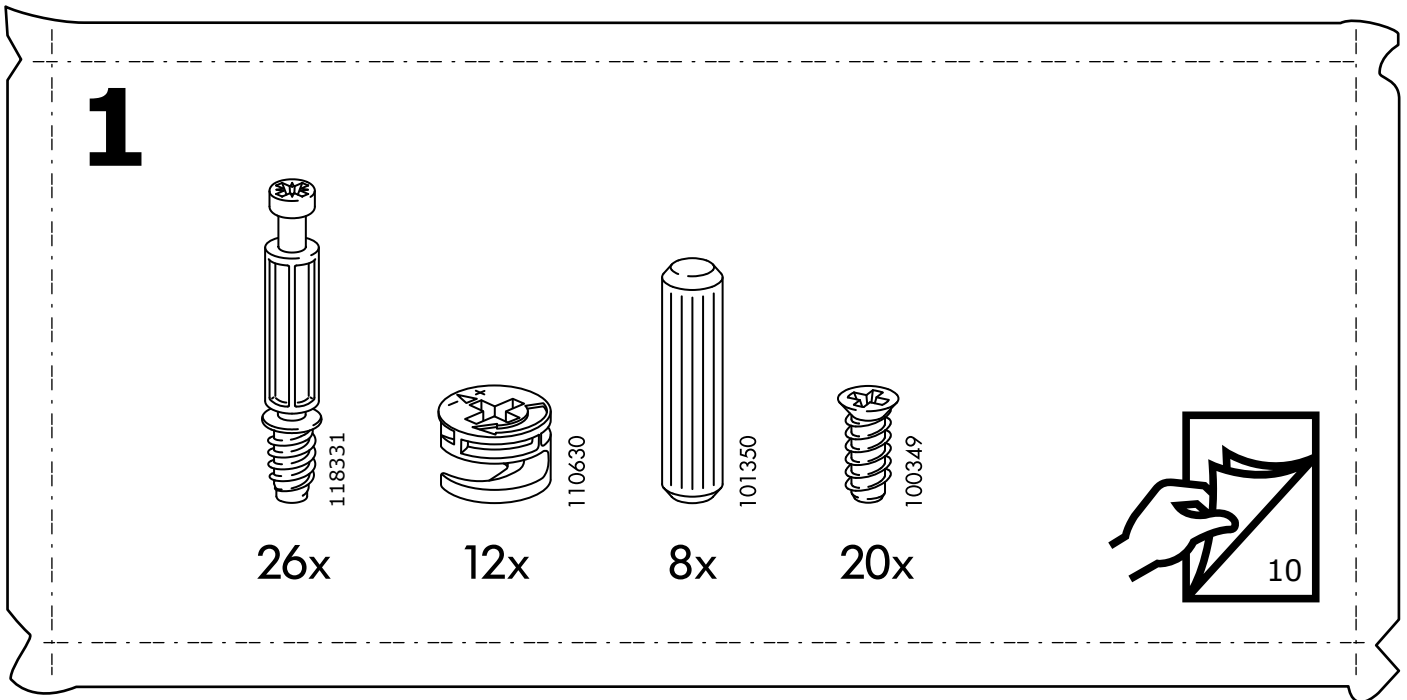
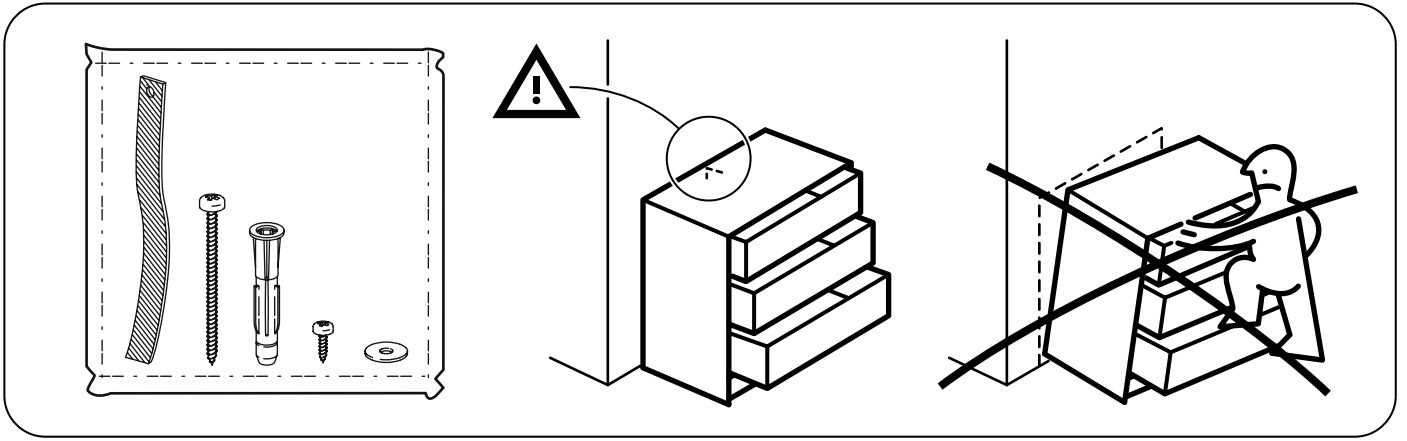

# 2

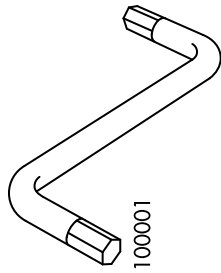

1x

100001

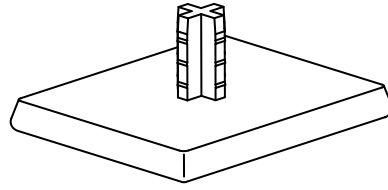

4x

157876  
157877  
158569  
158570



18x

110630

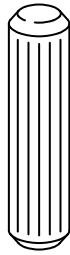

20x

101350

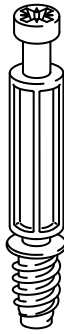

4x

118331  
112996

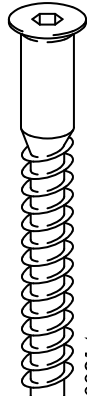

2x

100214

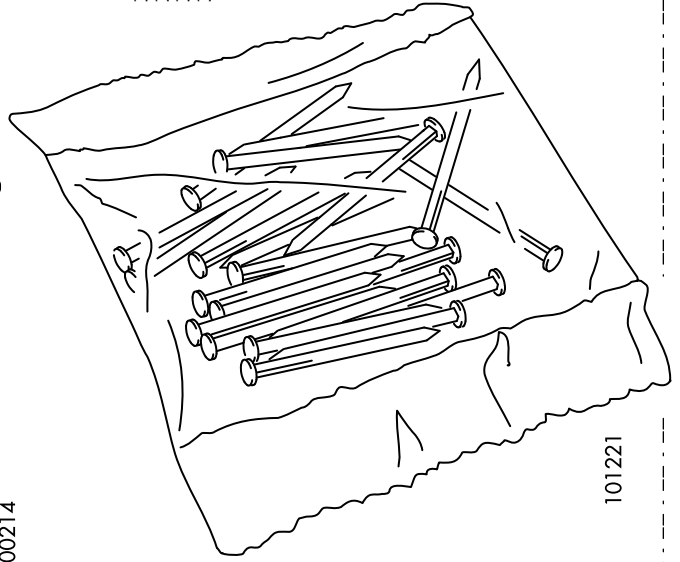

1x

101221

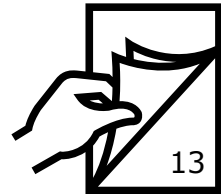

13

# 3

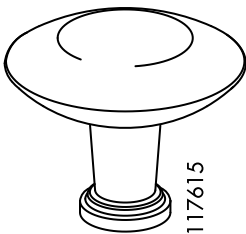

5x

117615

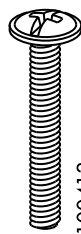

5x

100413

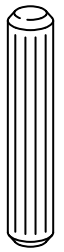

18x

101345

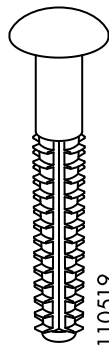

22x

110519

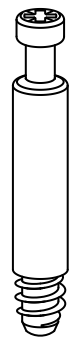

20x

123492

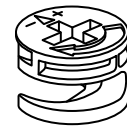

20x

110630



20x

100347



24



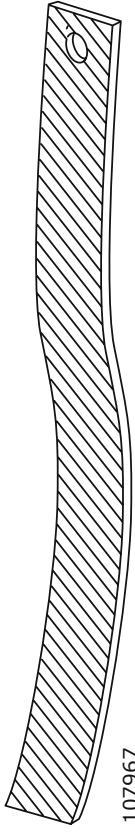

107967

1x

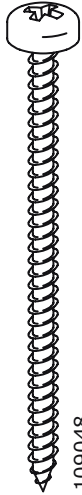

109048

1x

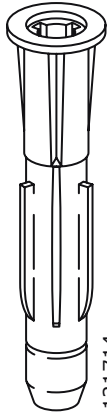

121714

1x



109049

1x



100823

2x

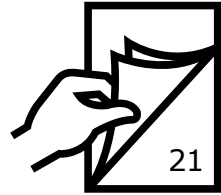

21

1

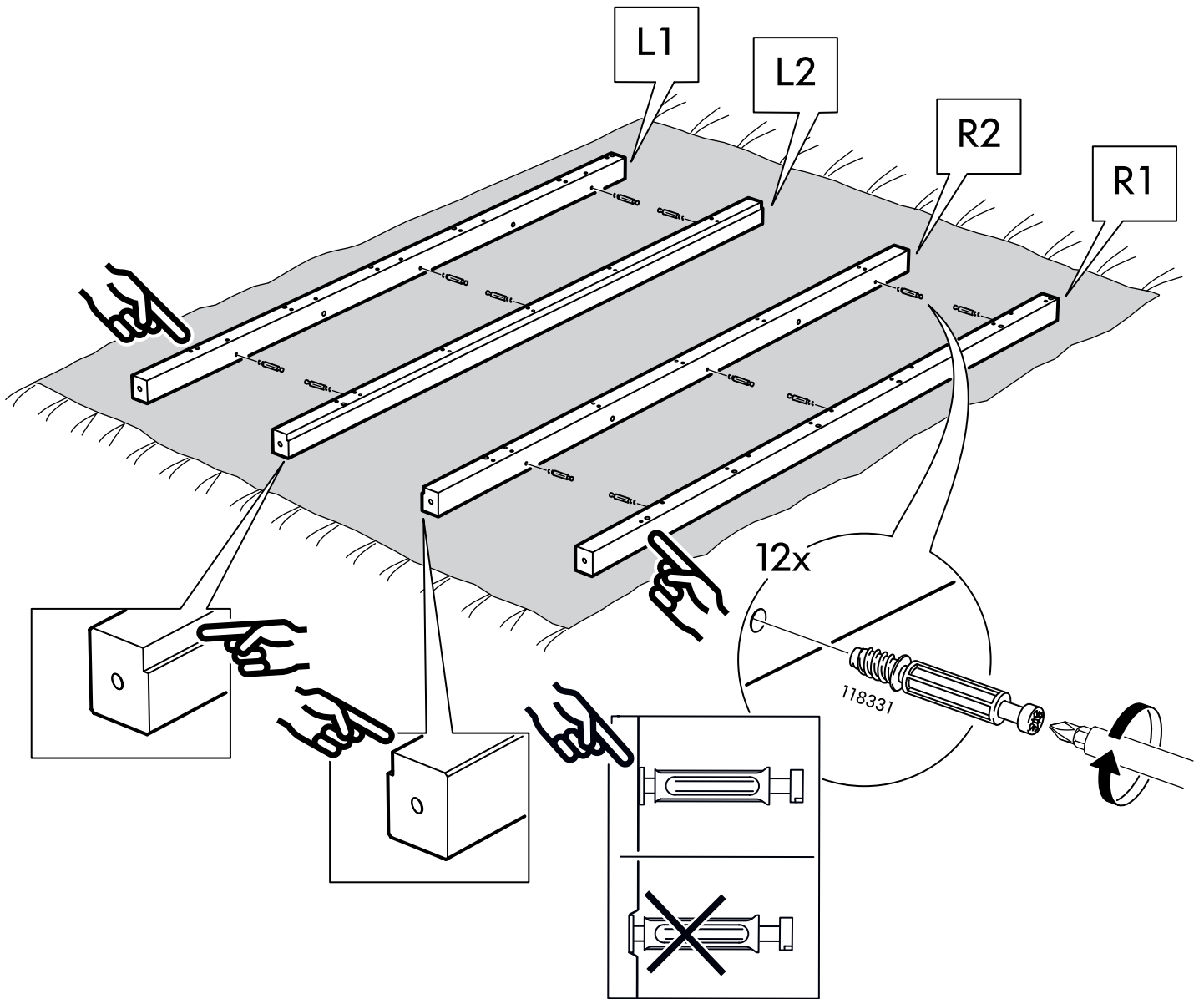
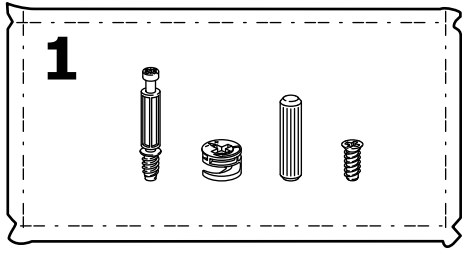

**2**

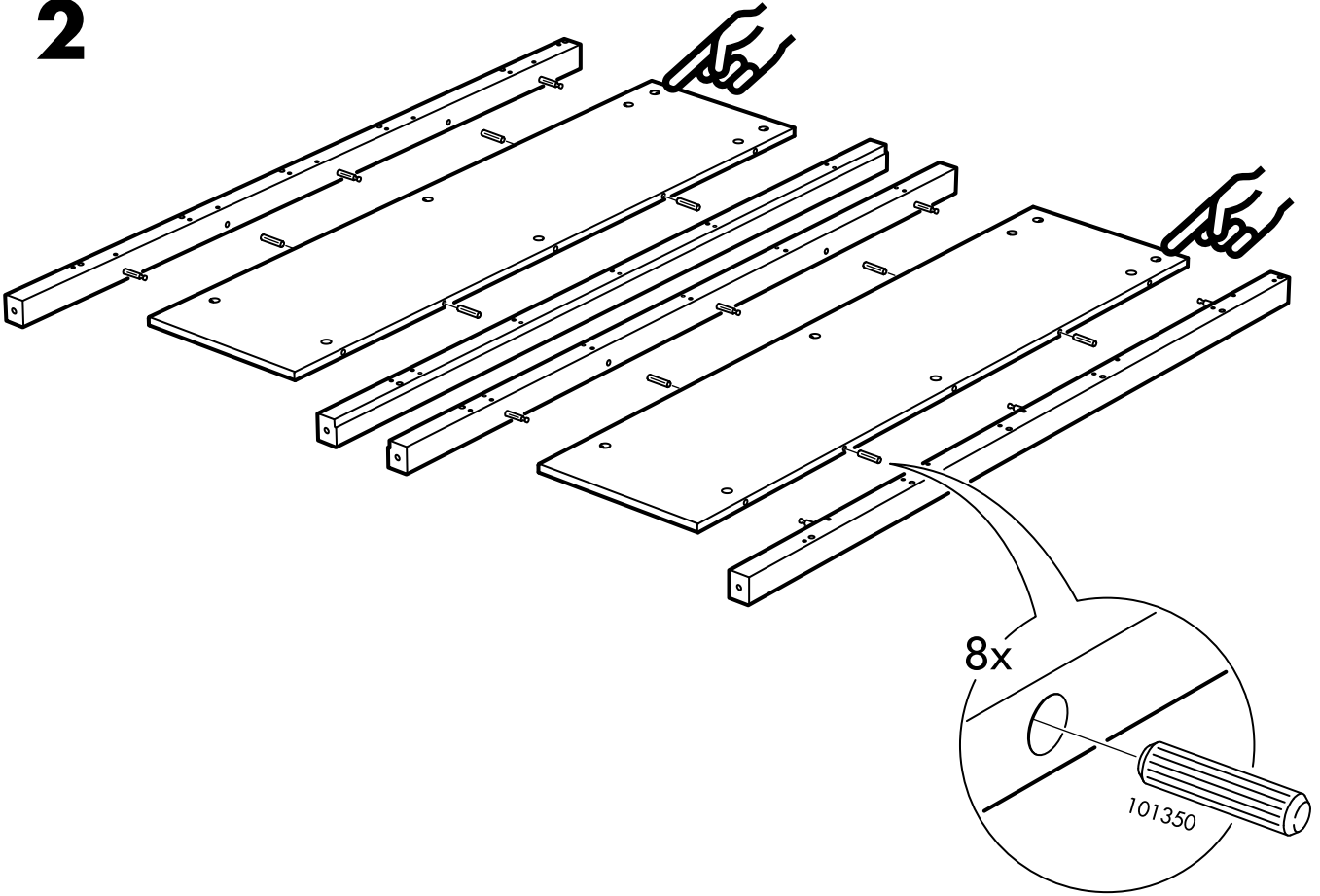

**3**

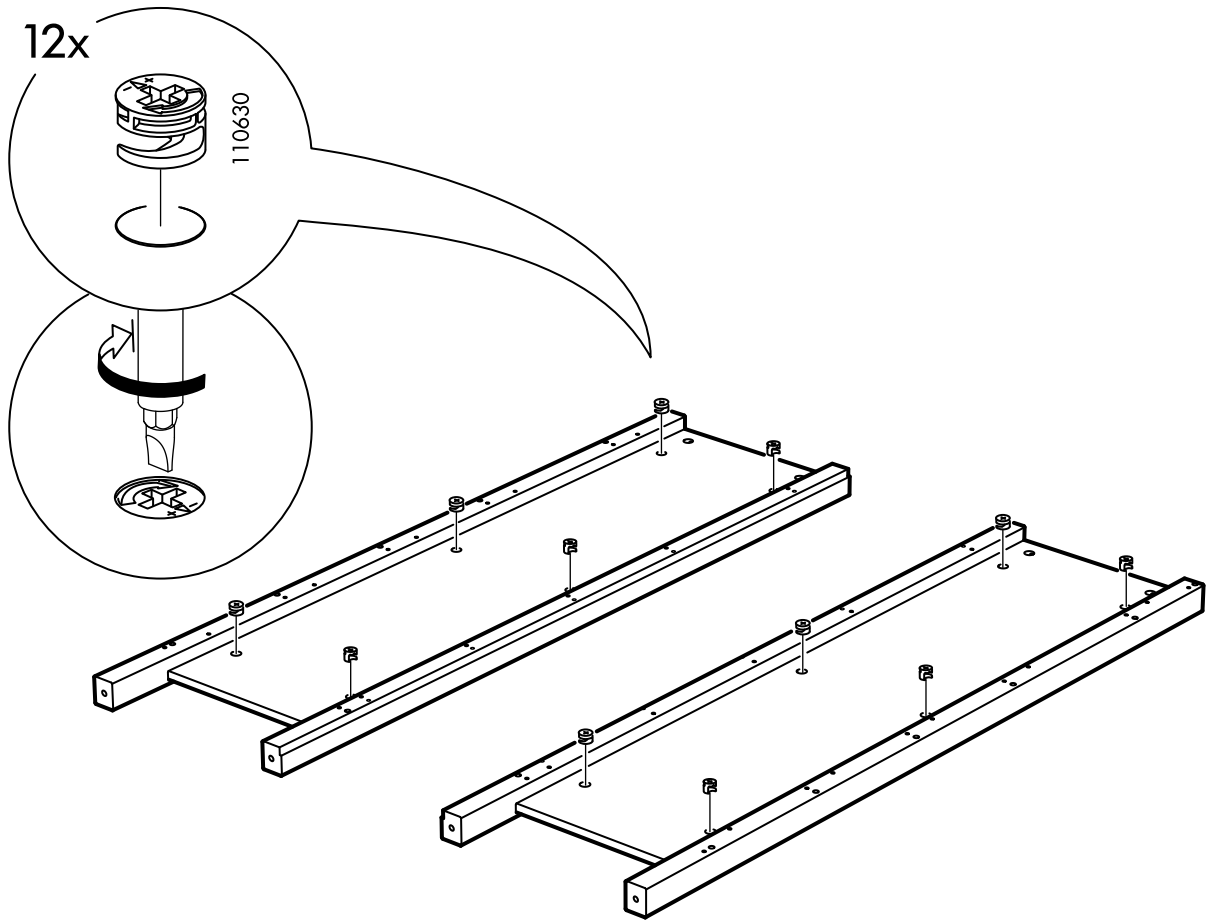

# 4

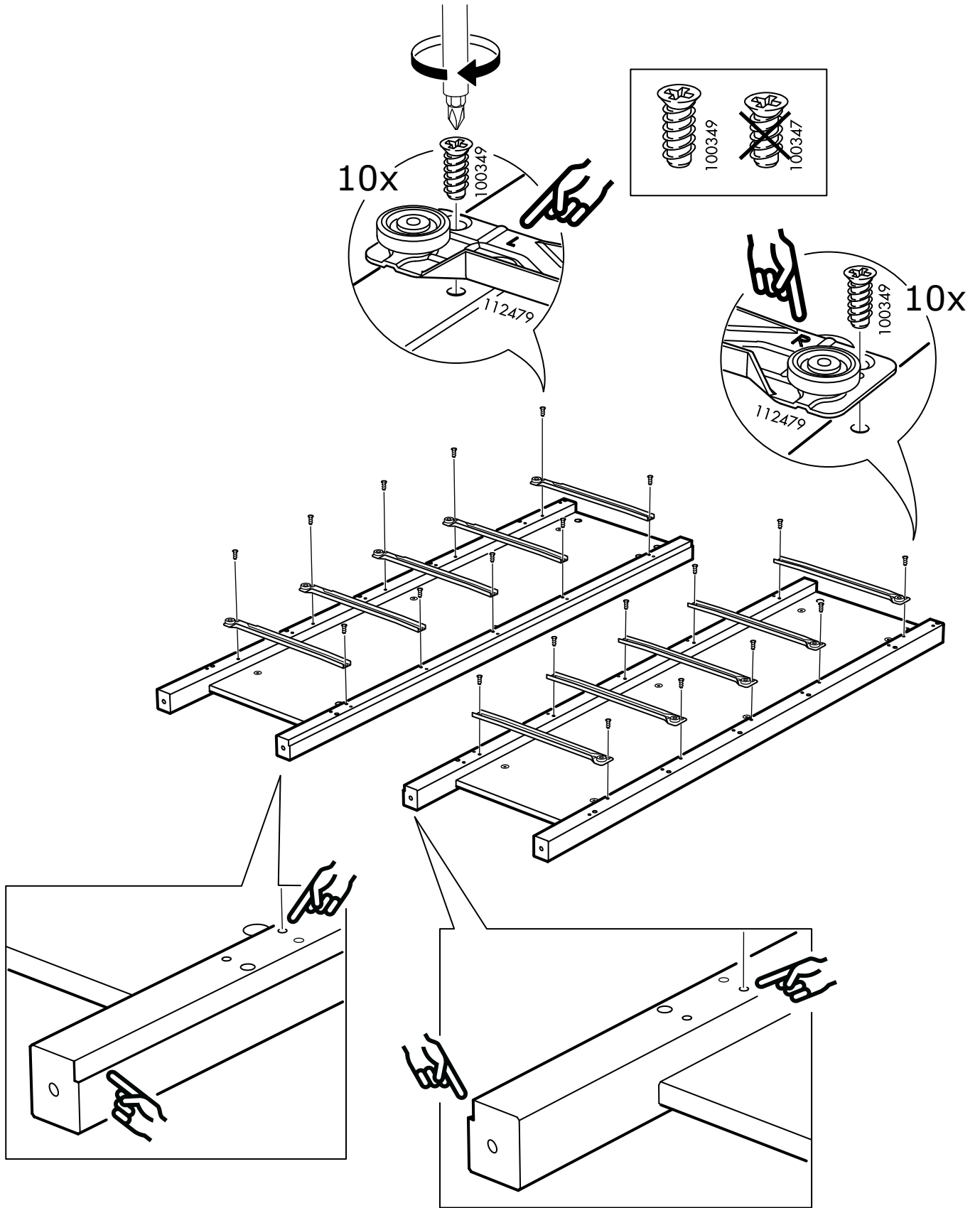

5

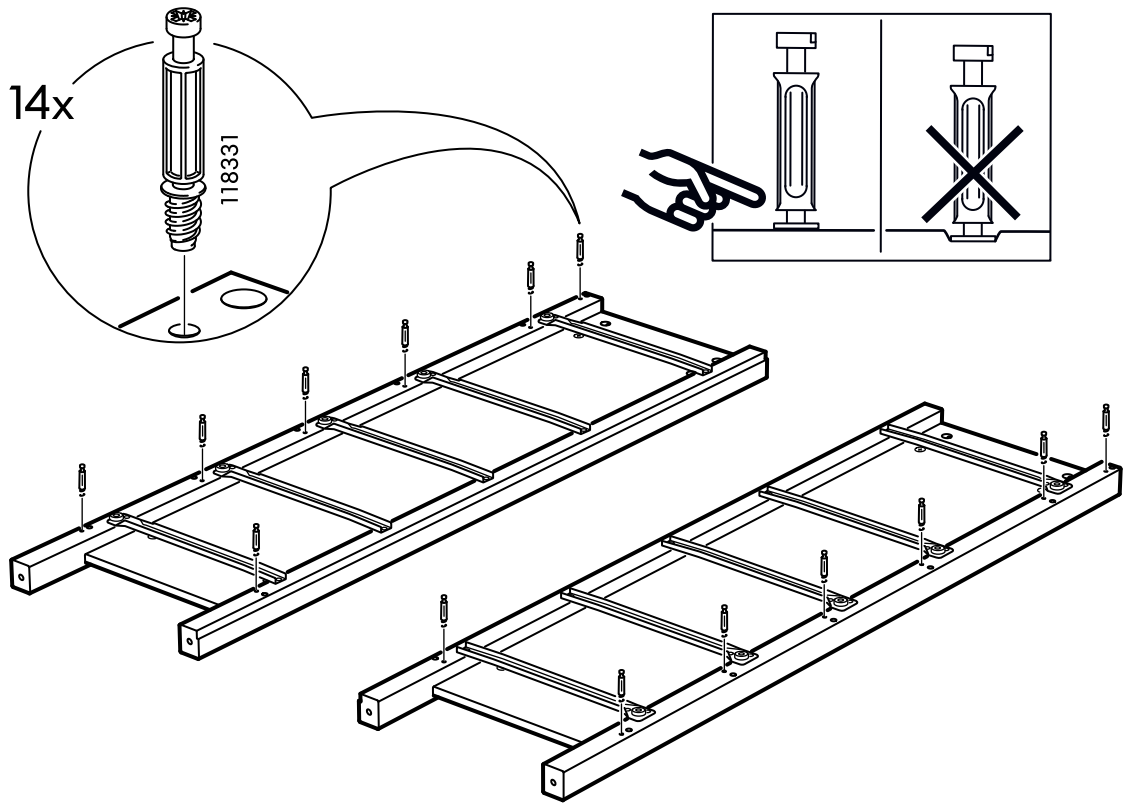

6

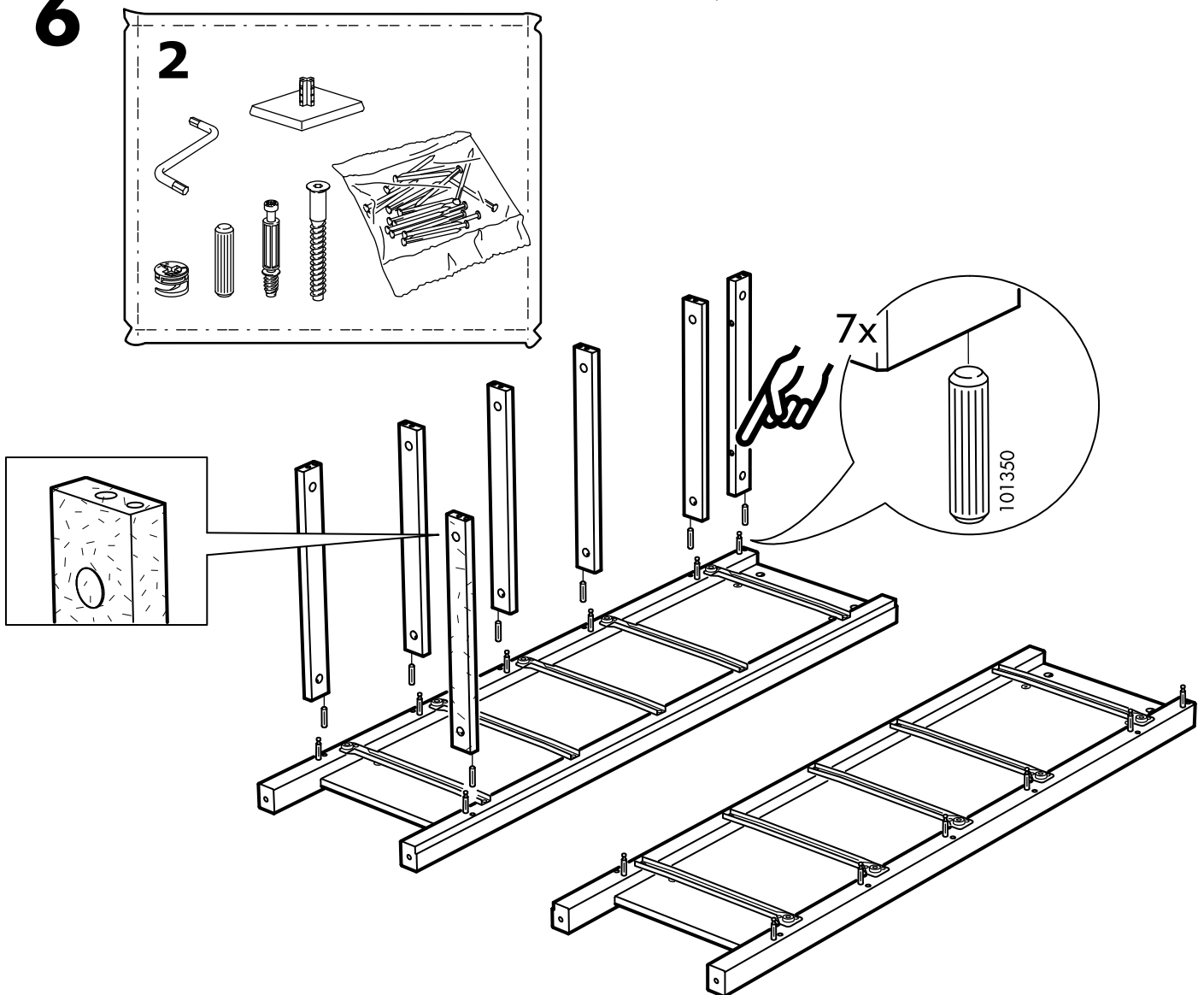

7

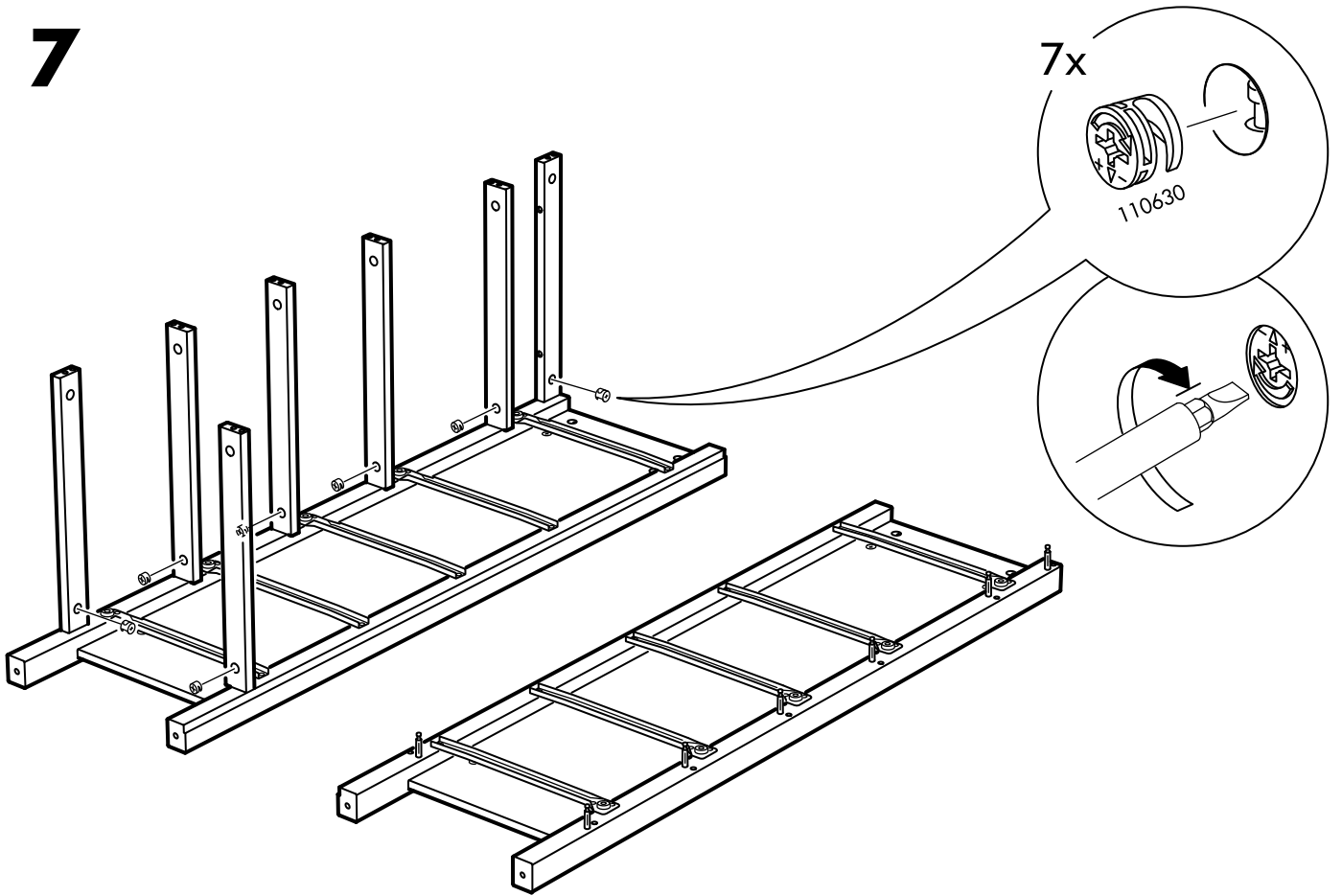

8

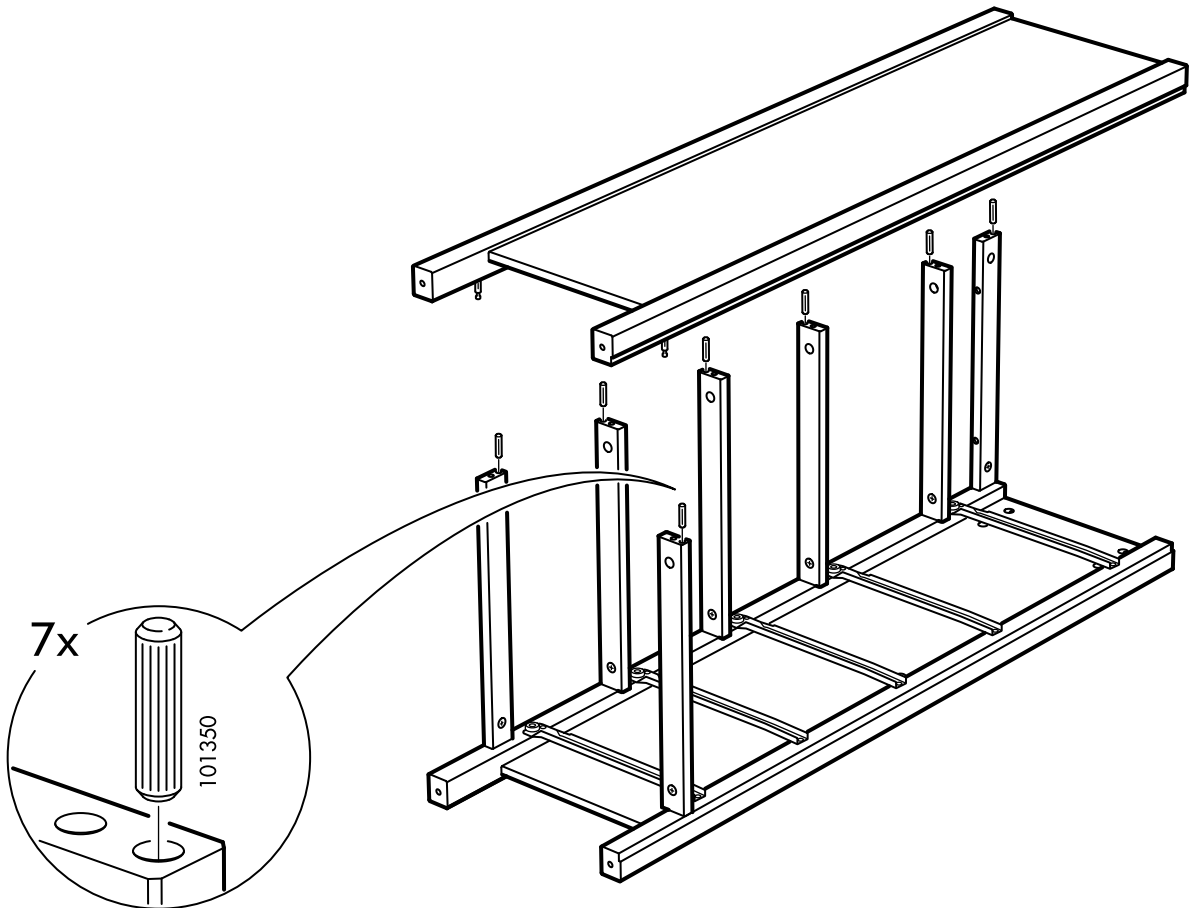

9

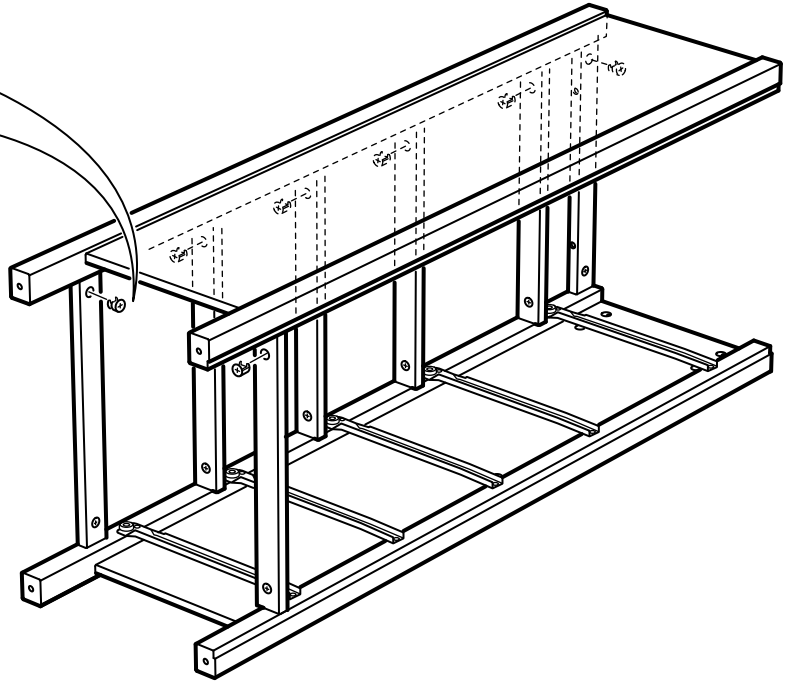
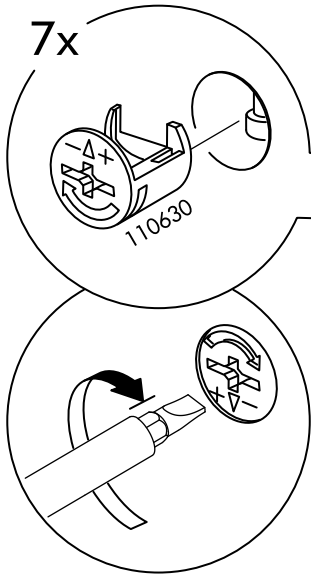

10

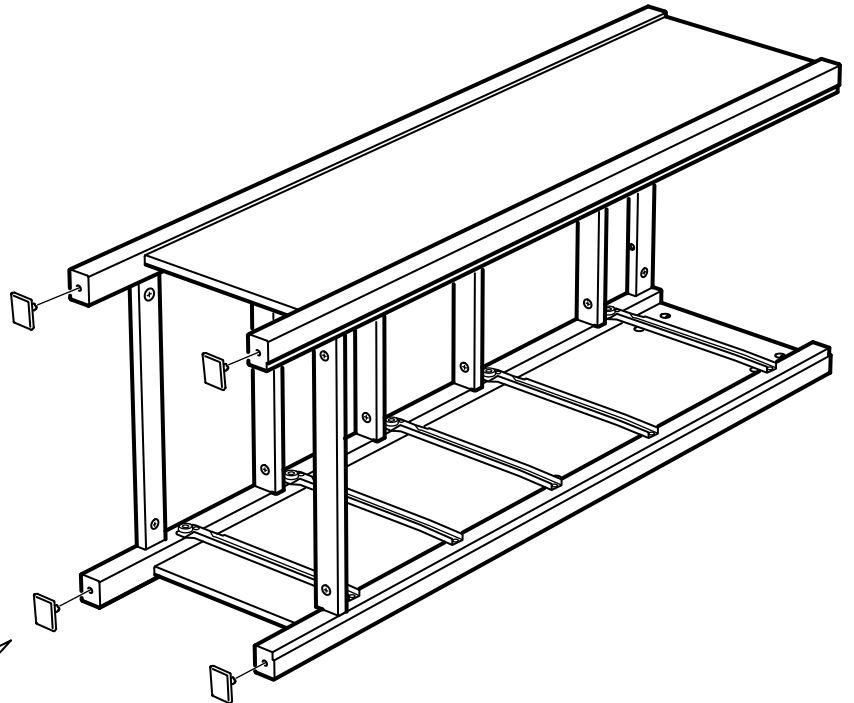
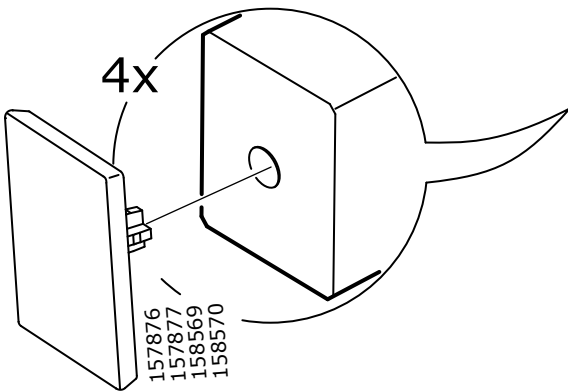

11

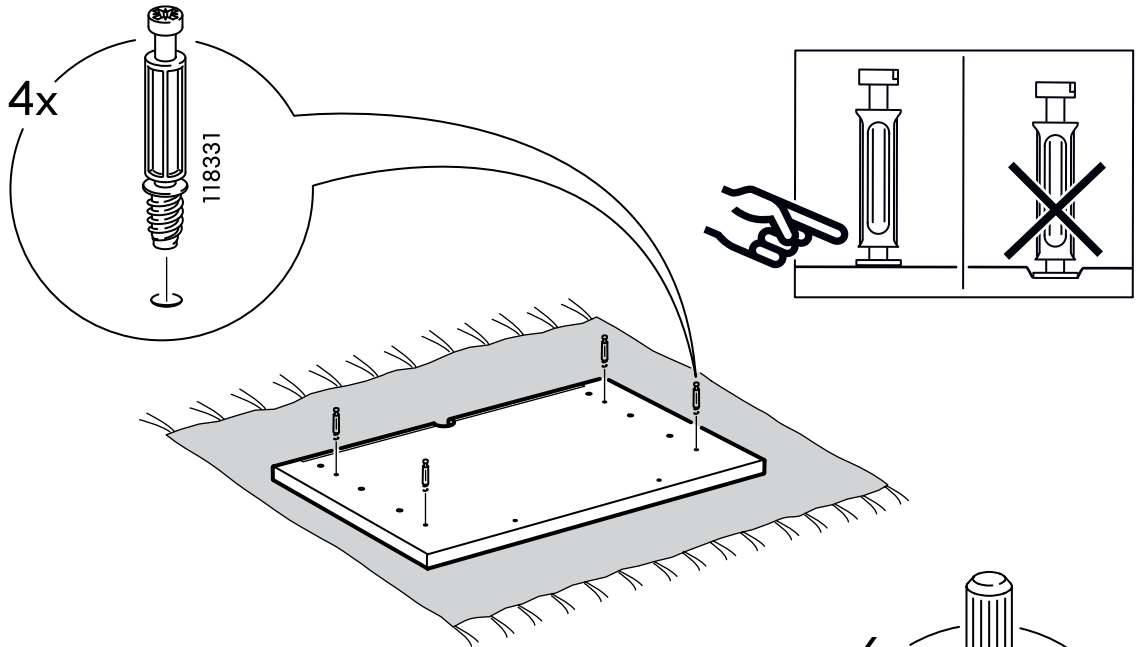

12

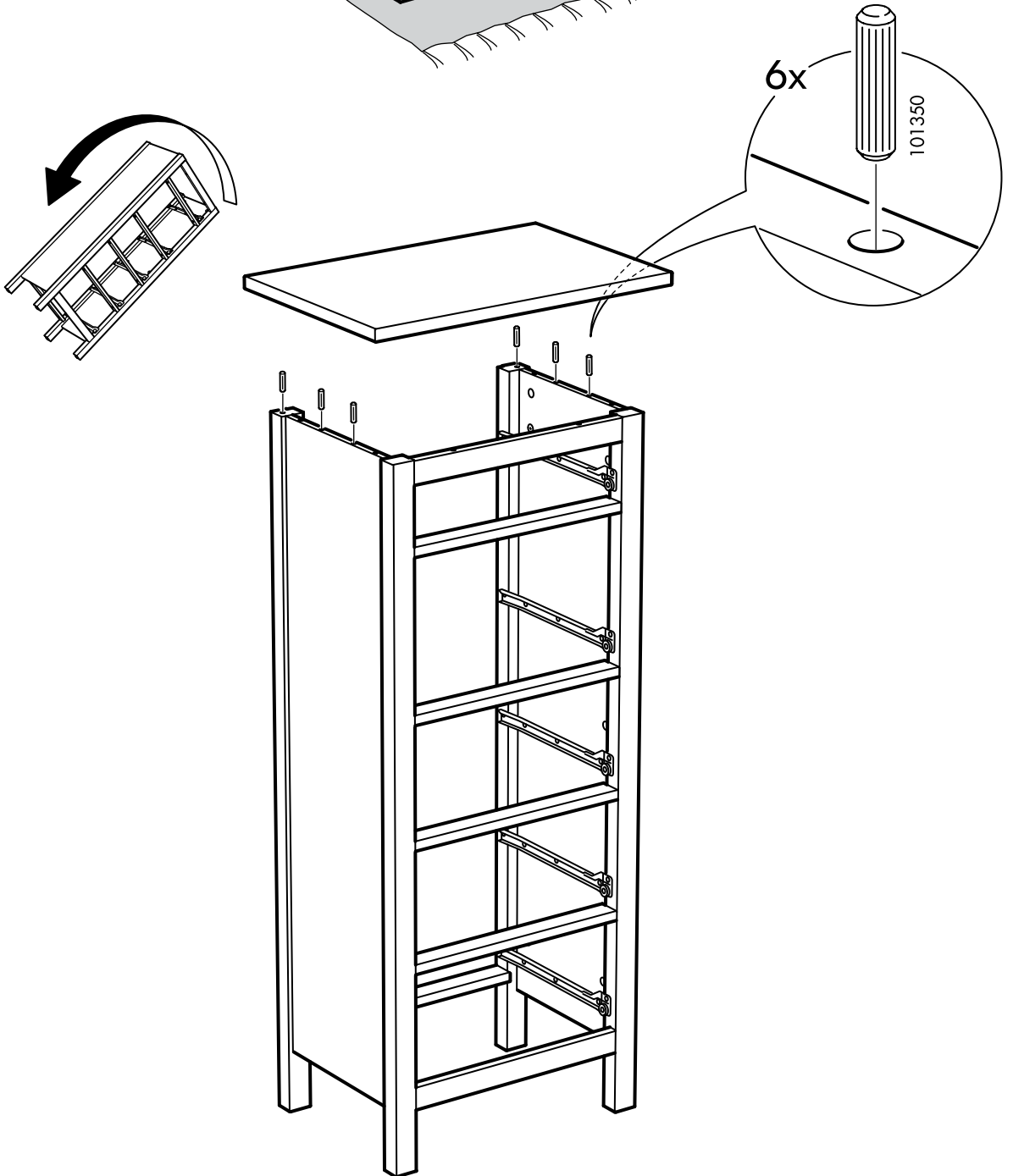



# 13

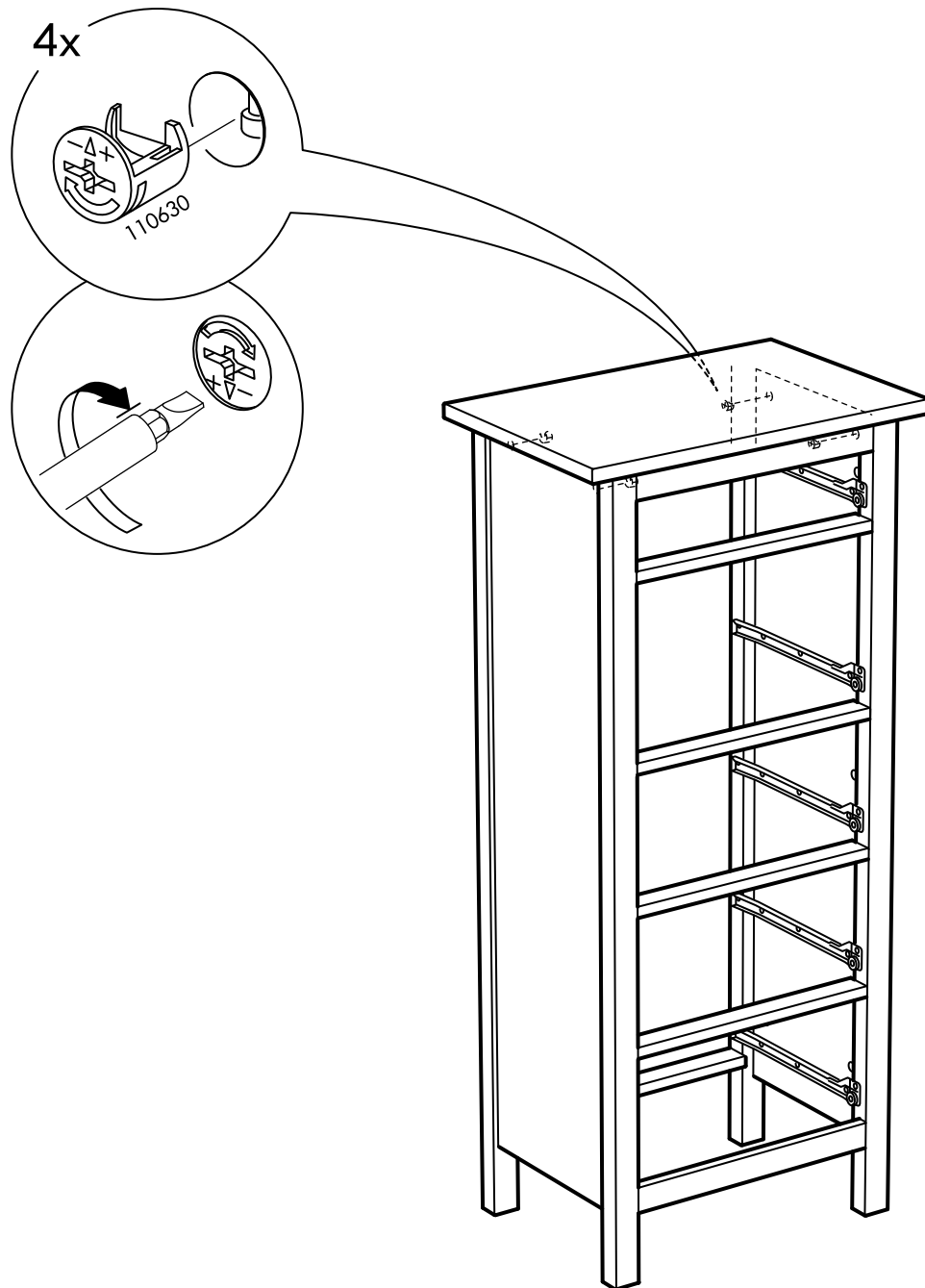

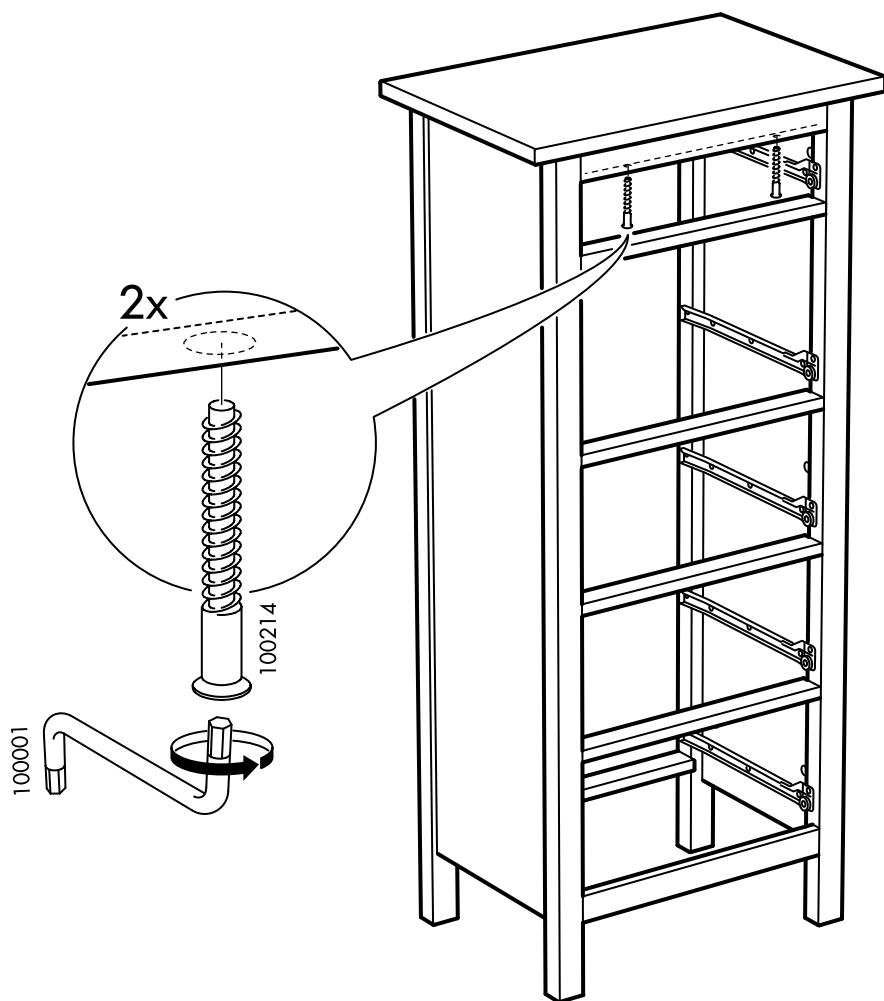

15

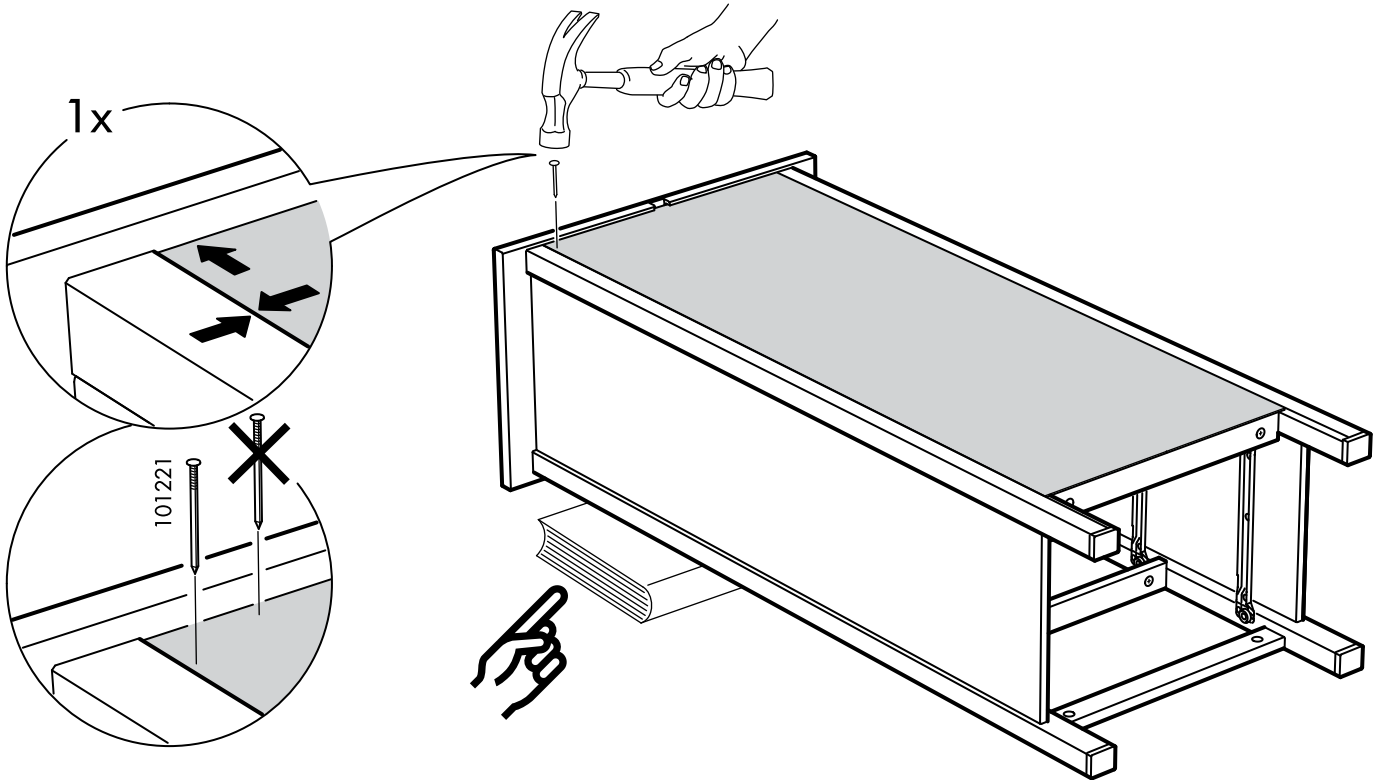
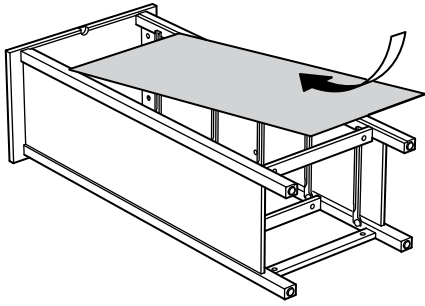

16

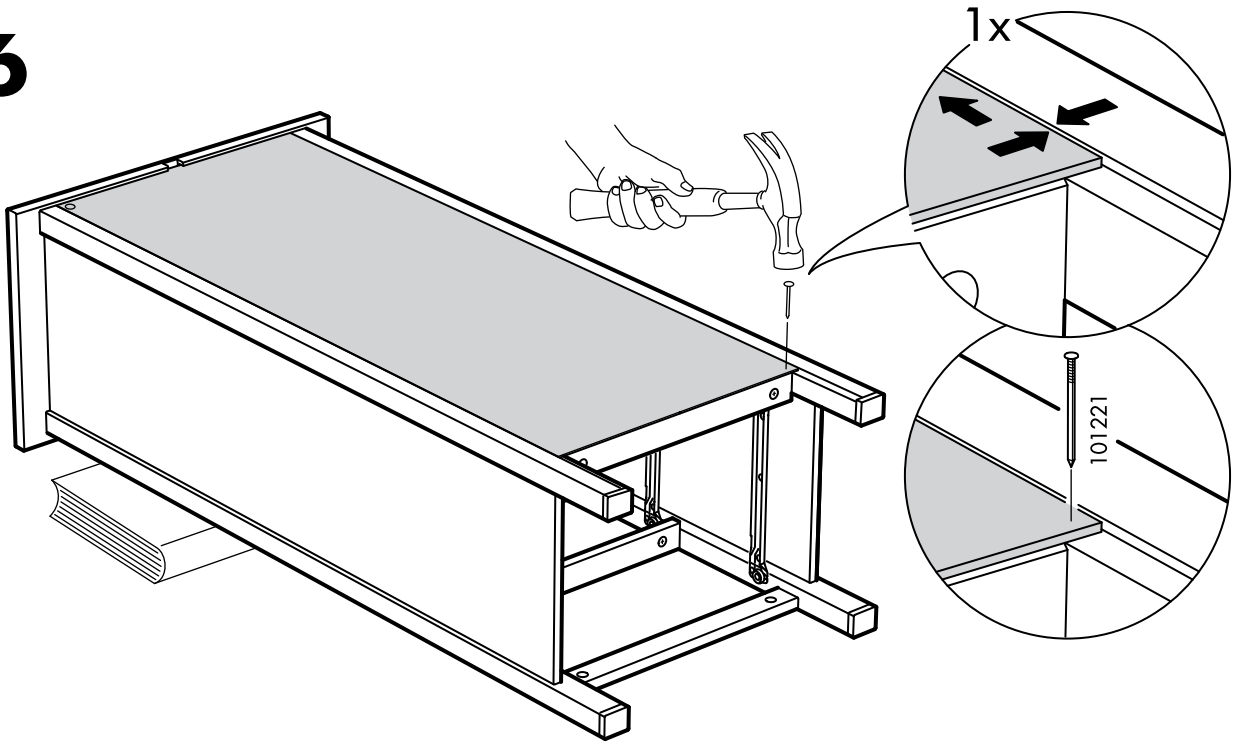

17

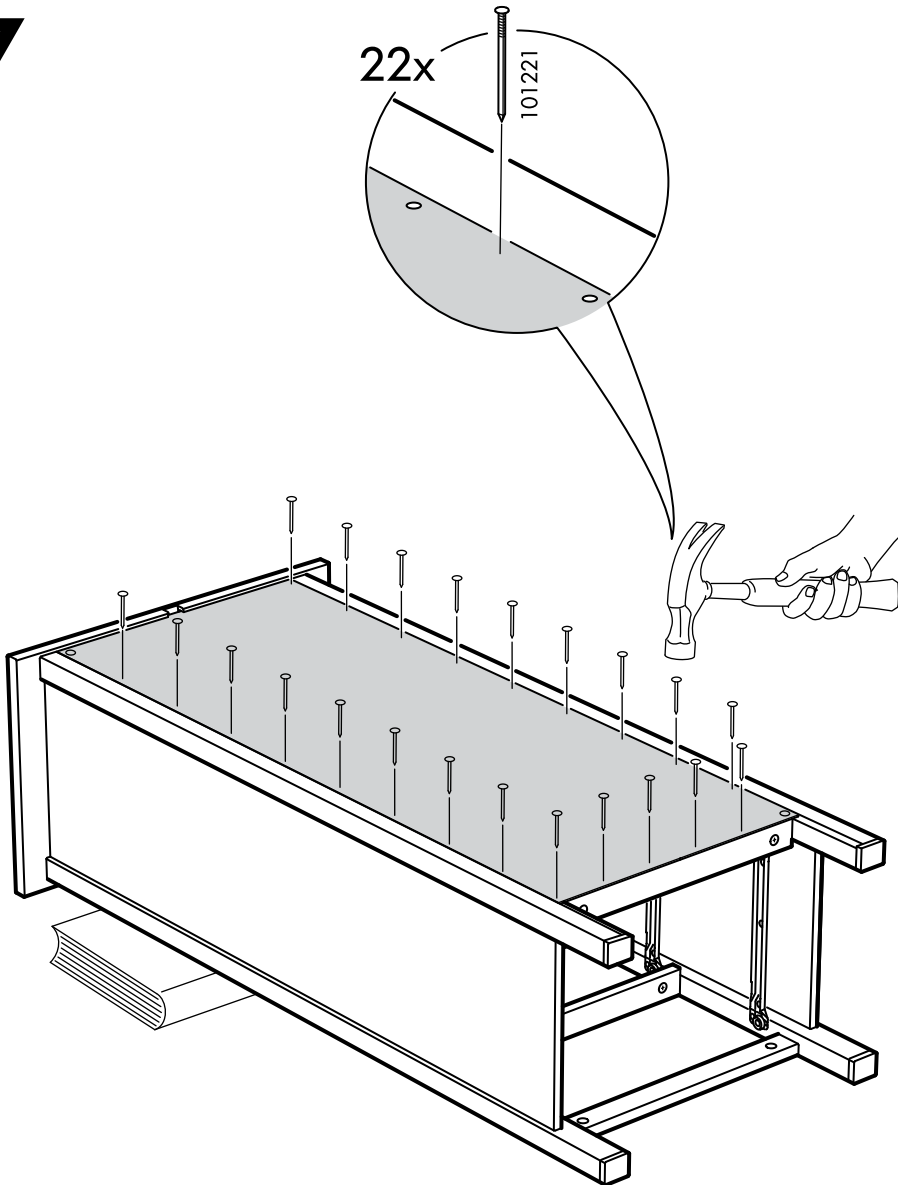

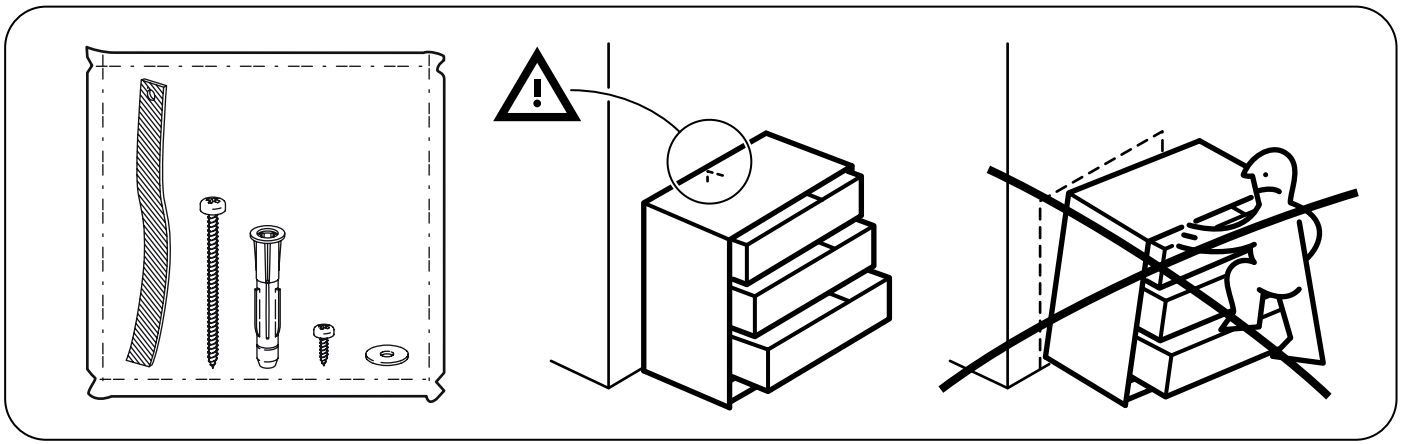

**18**

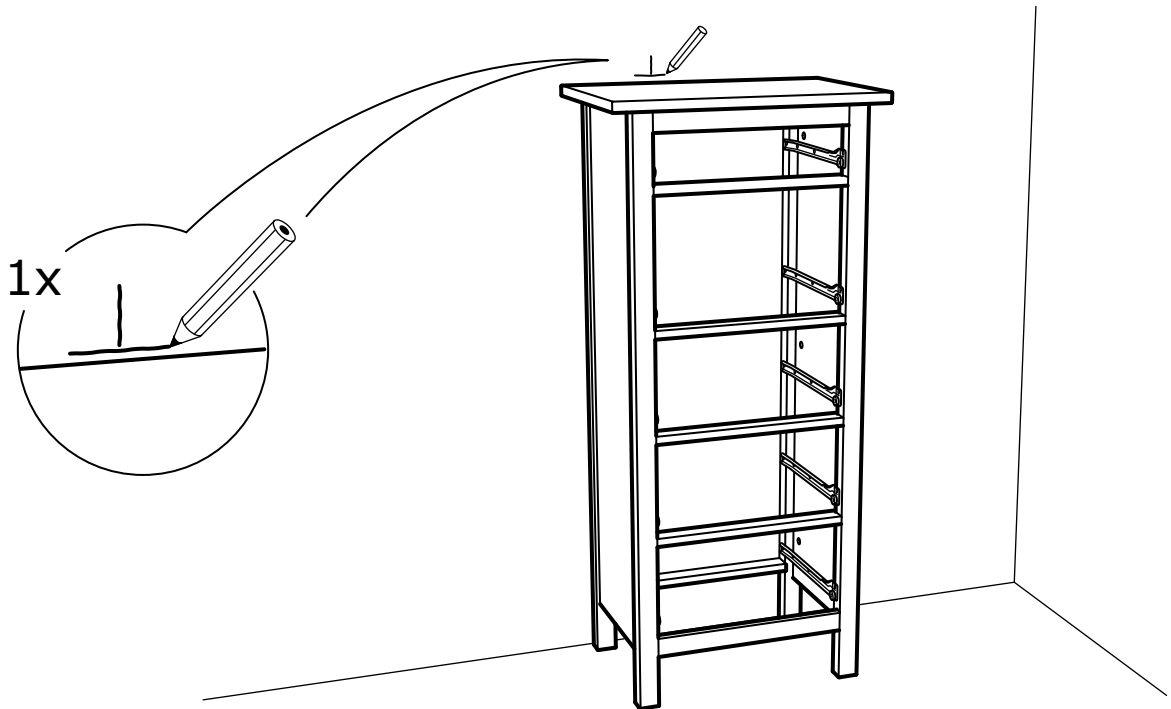
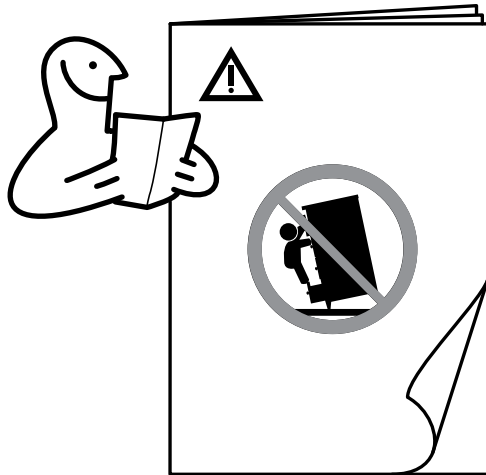

# 19

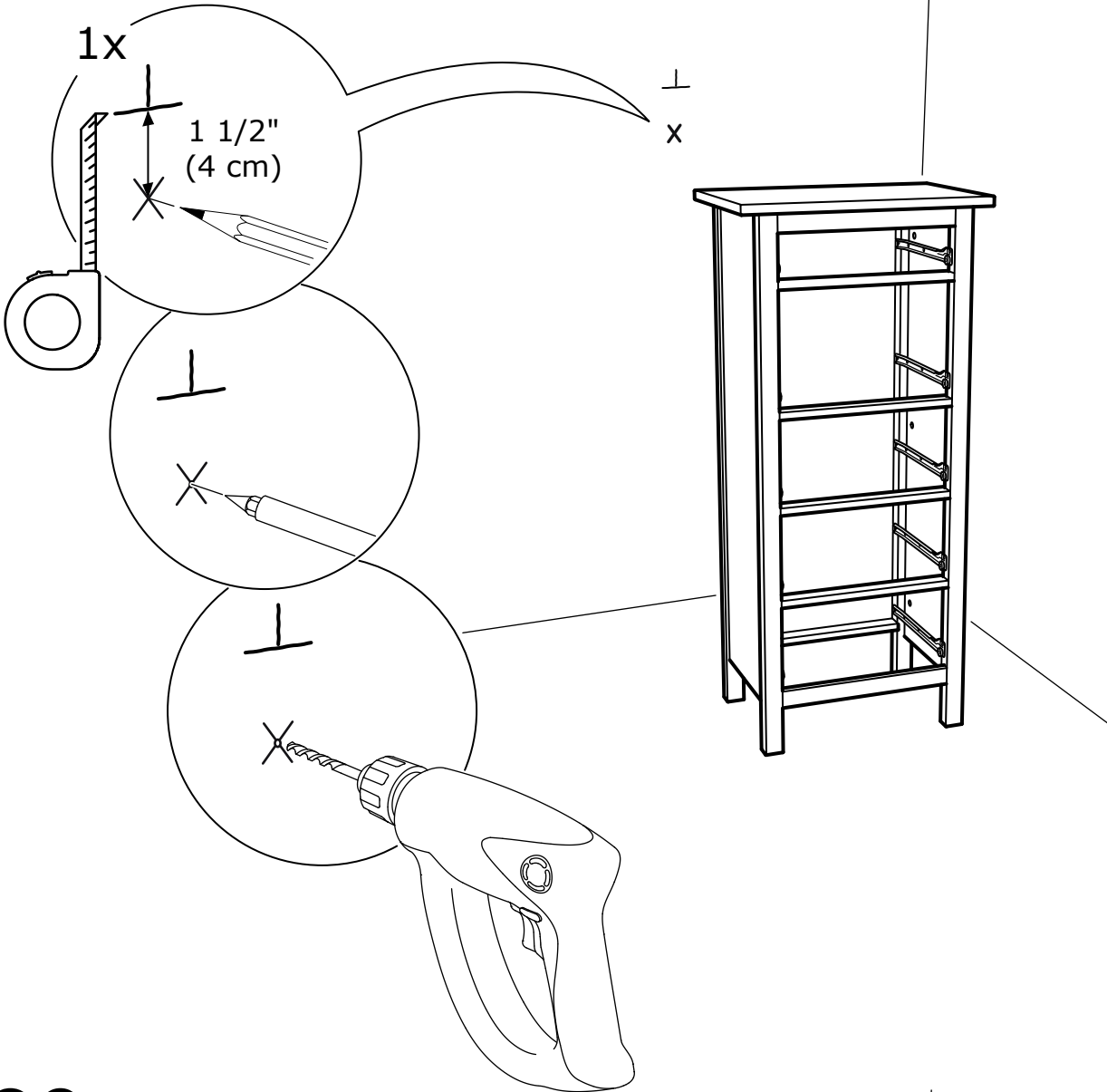

# 20

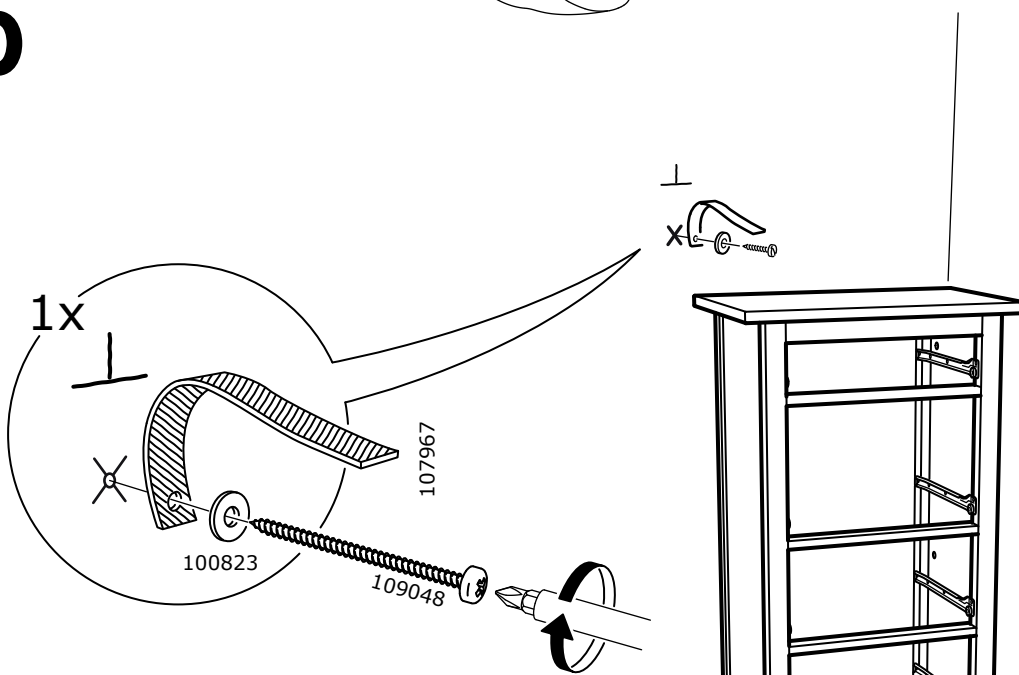

# 21

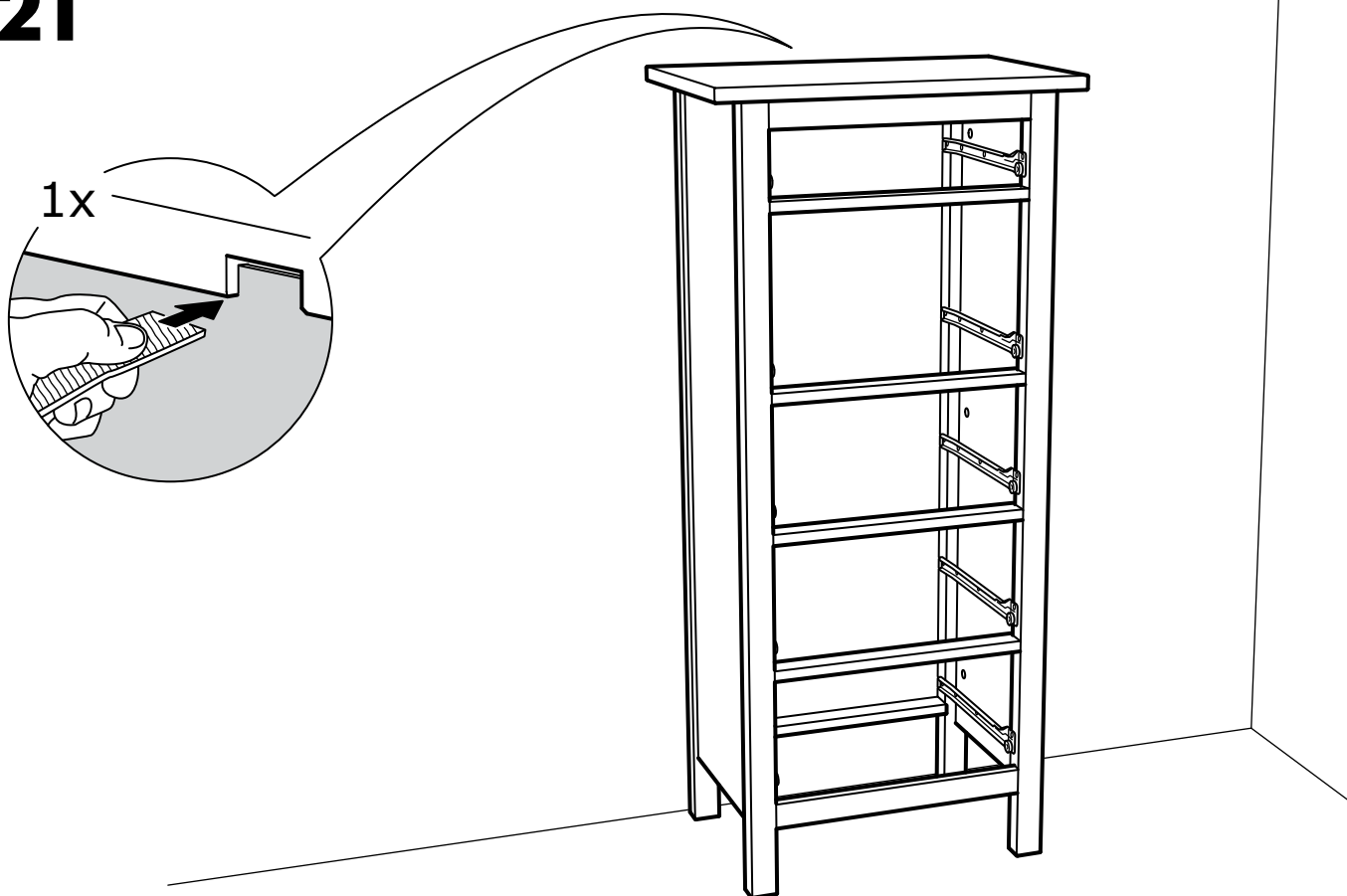

# 22

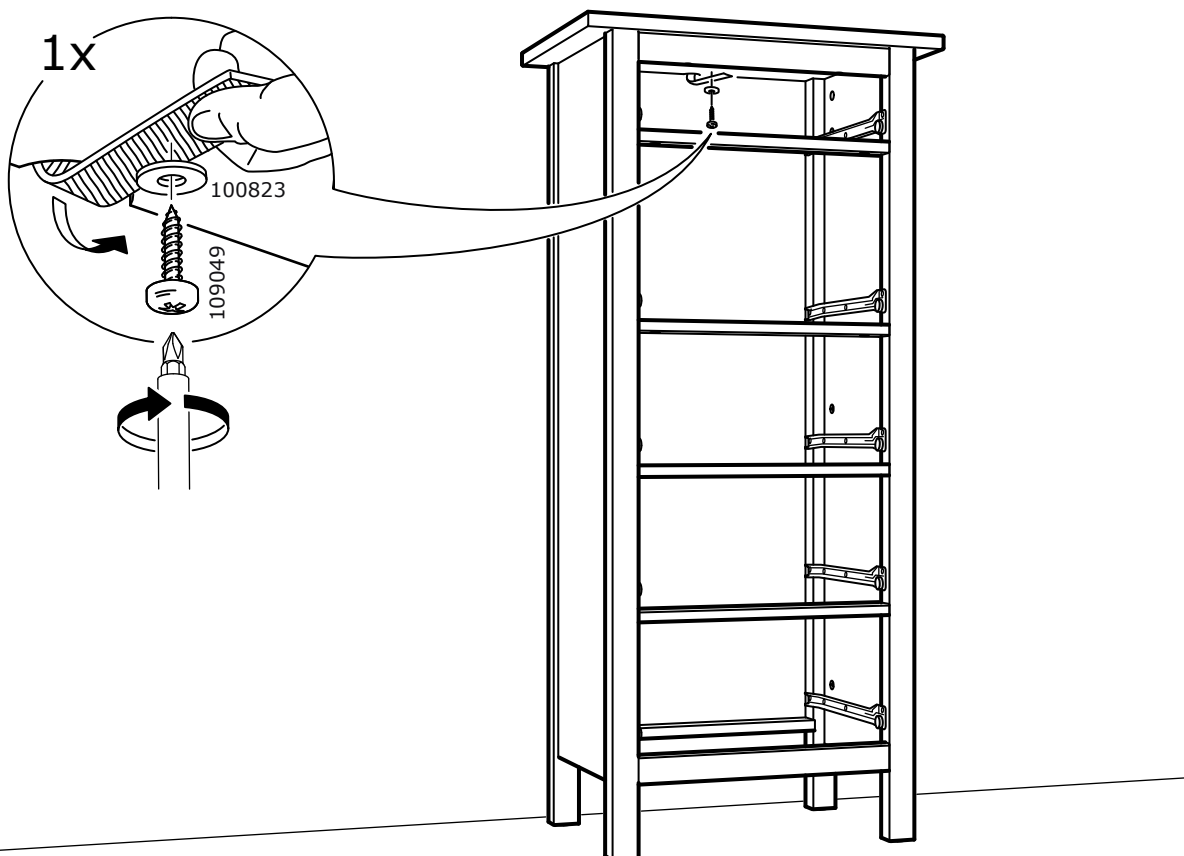

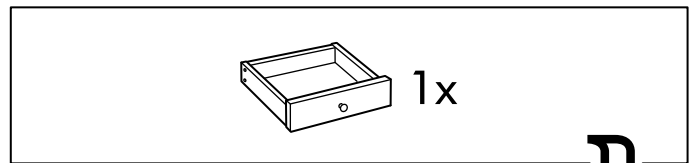
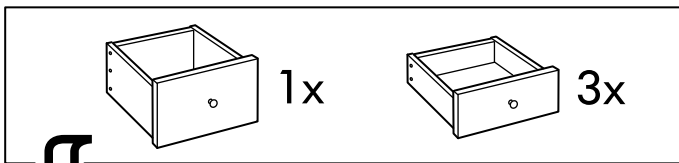

**23**

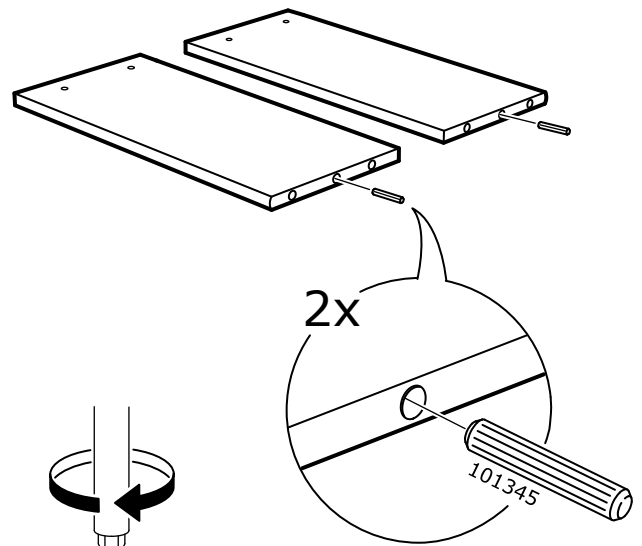
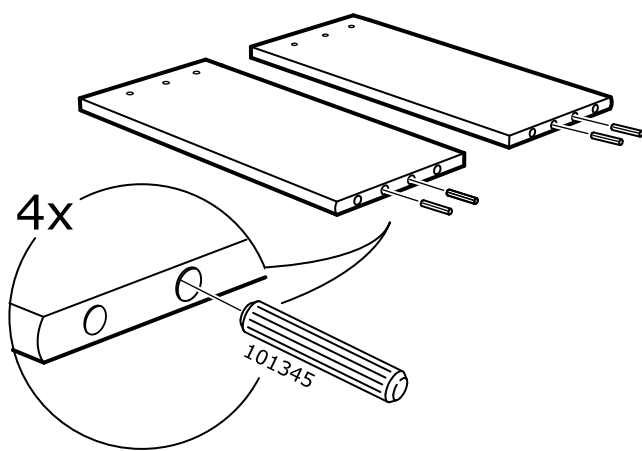
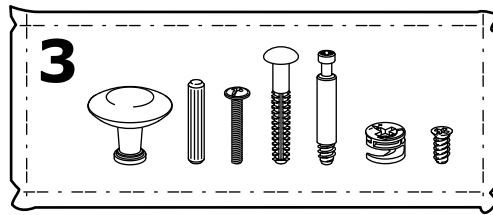

**24**

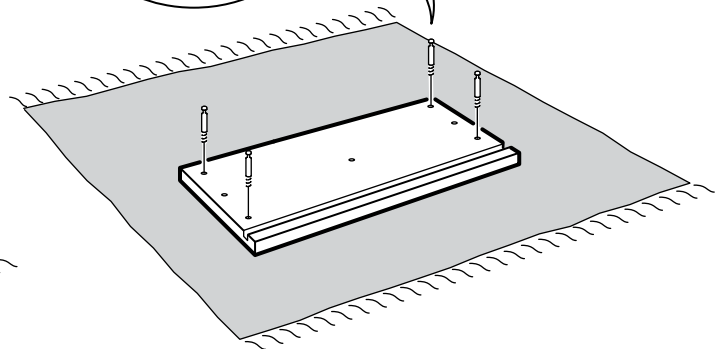
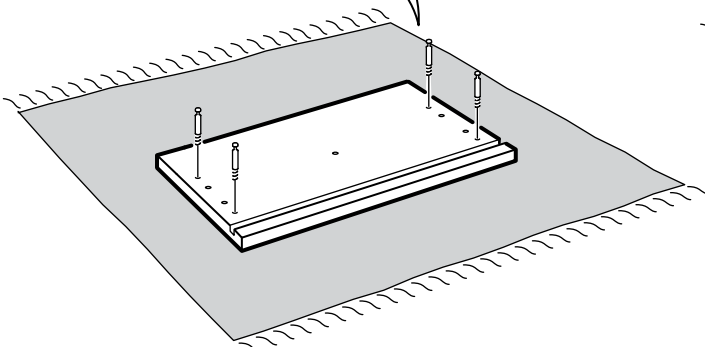
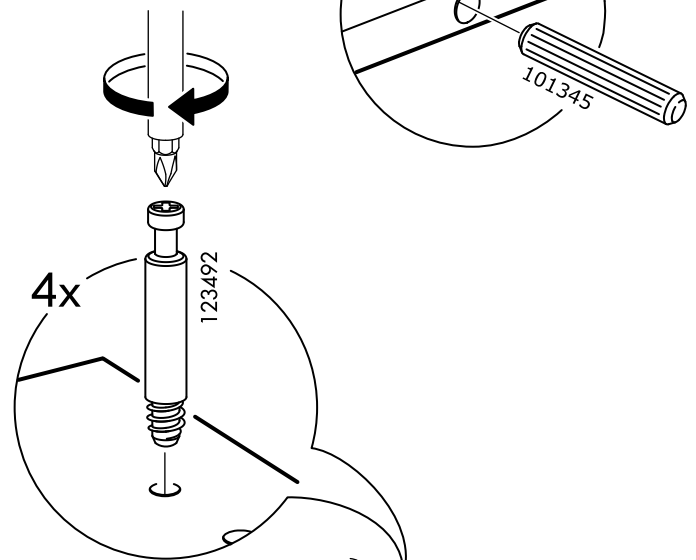
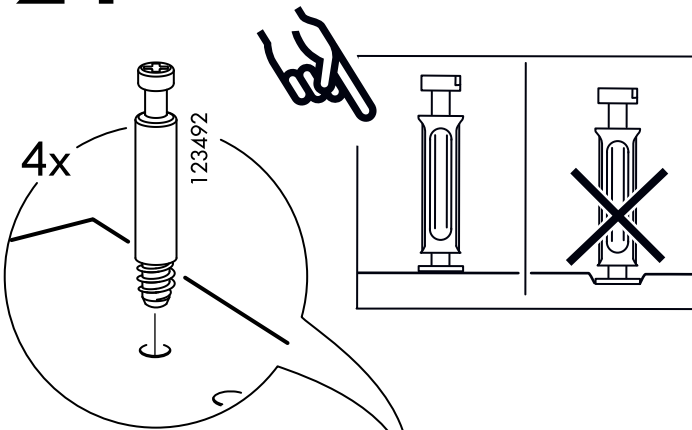



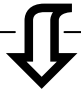
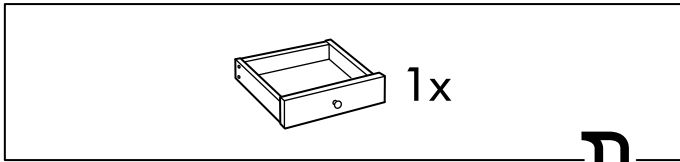
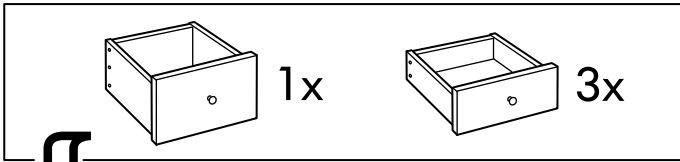

# 25

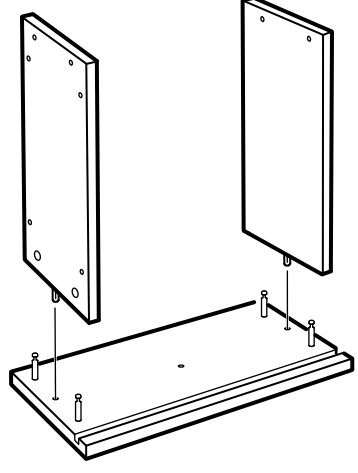
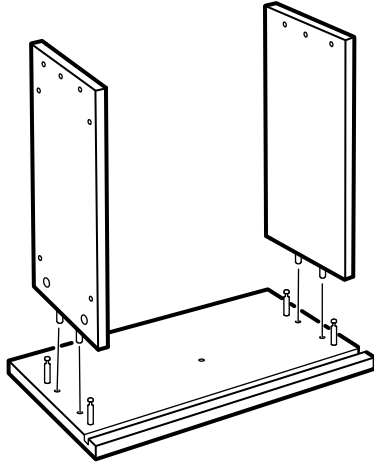

# 26

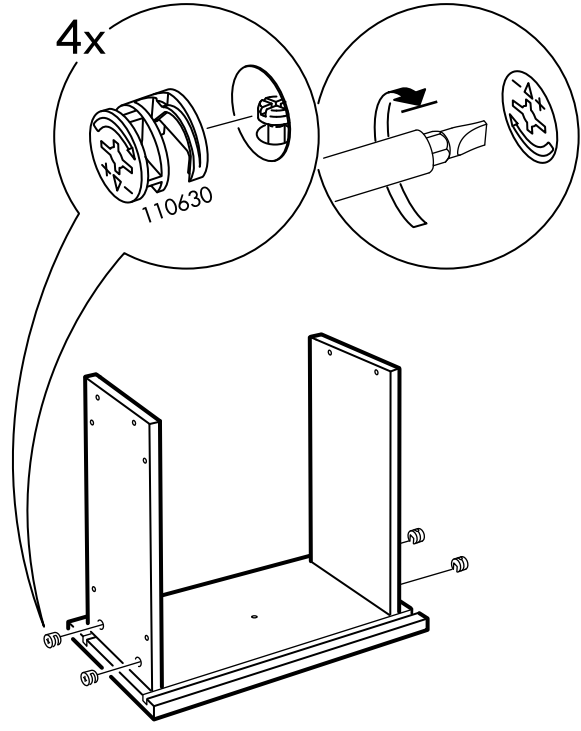
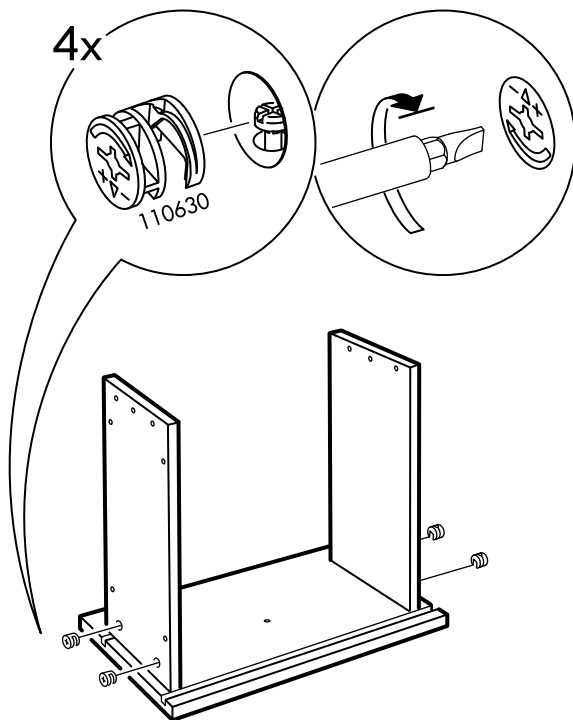

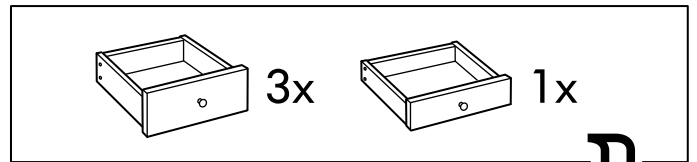
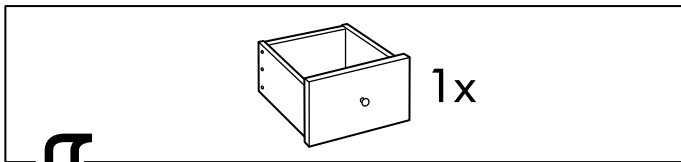

# 27

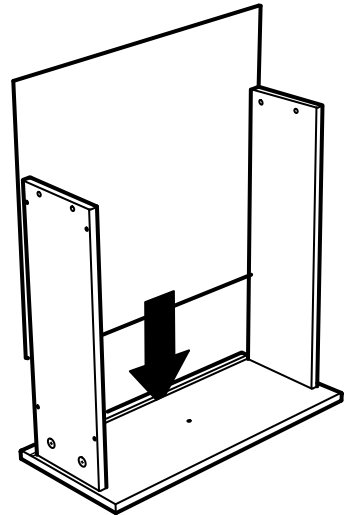
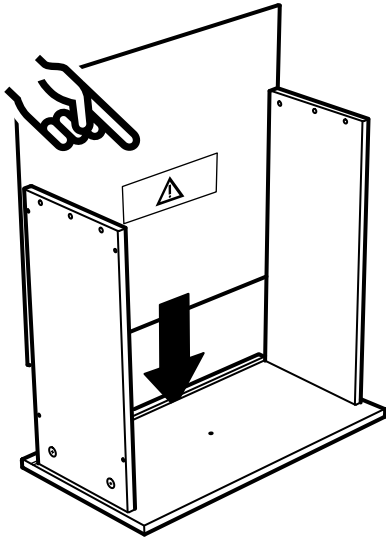

# 28

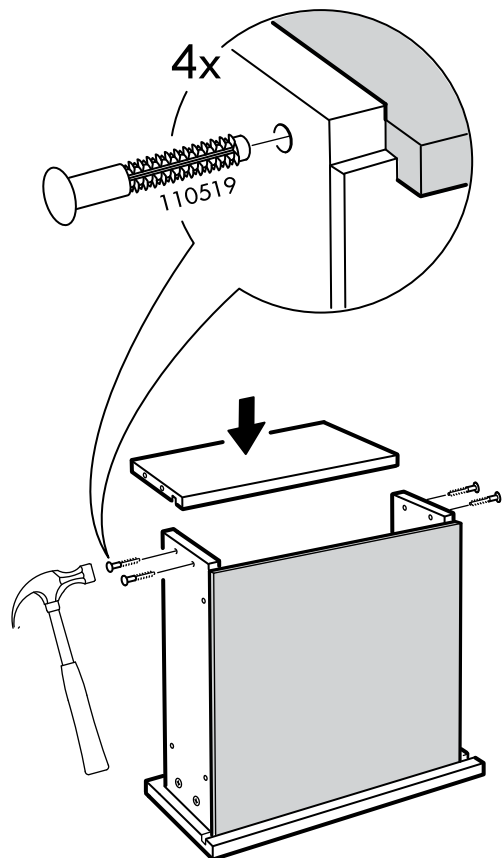
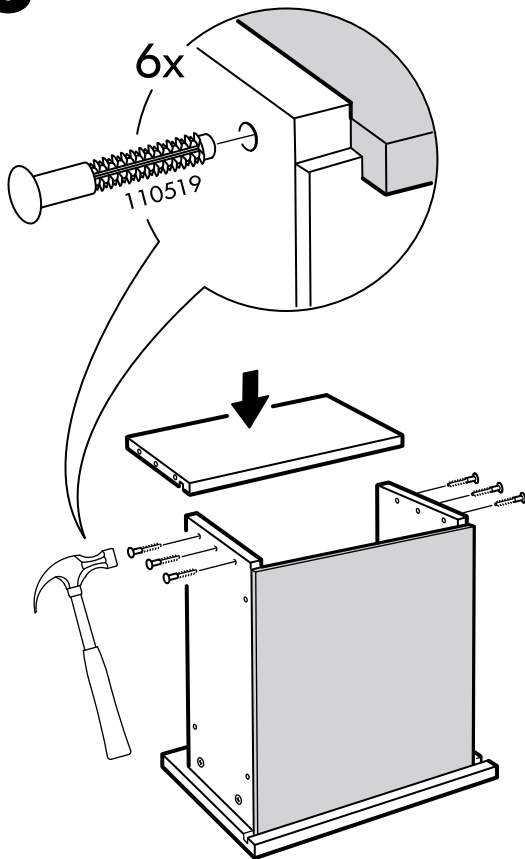

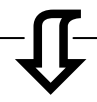
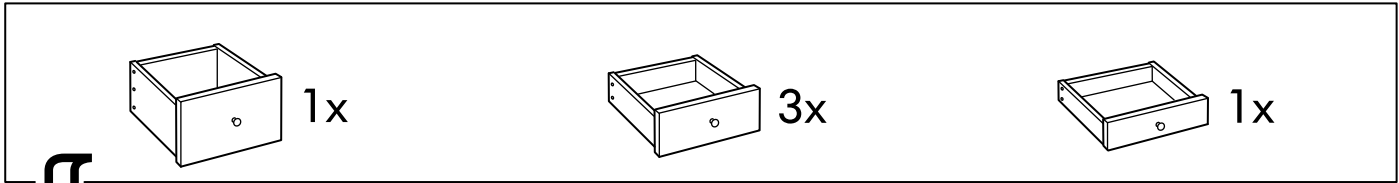

**29**

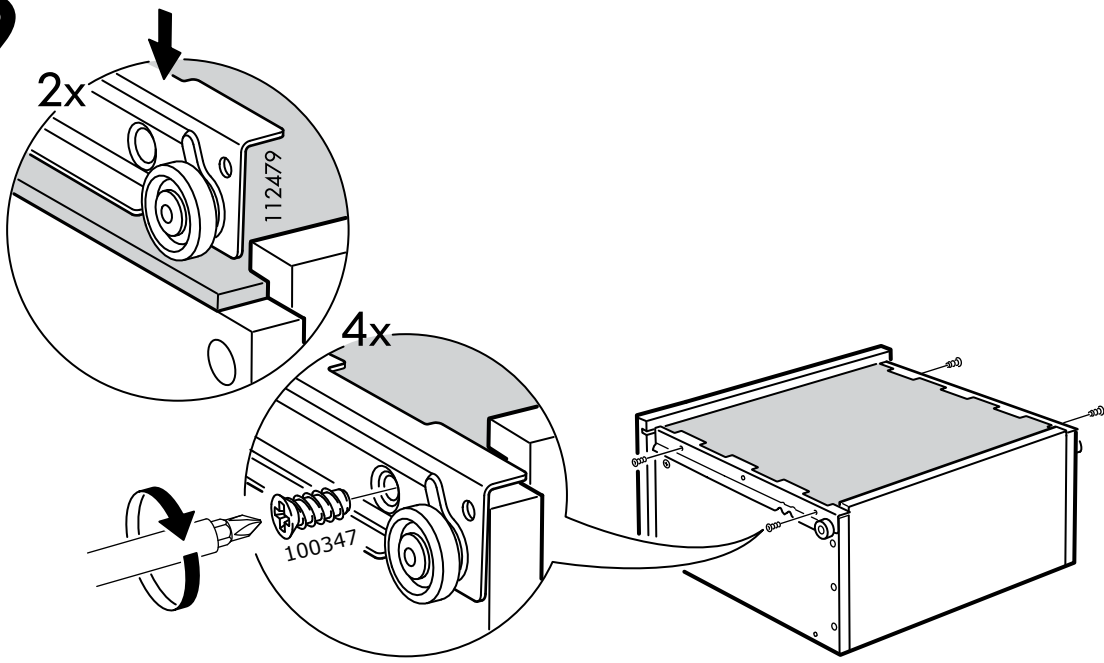

**30**

